



INSTALLATION AND OPERATION INSTRUCTIONS OVERHEAD RADIANT TUBE HEATERS

Models: CBU09, CBU12, CBU15, SRU25, ERU25, SRU30, SRU35, SRU40, SRU45,
SRL09, SRL12, SRL15, SRL25, SRL30, SRL35, SRL40, SRL45

Single Stage Pull Through System (Negative Pressure)



OWNER / INSTALLER: For your safety this manual must be carefully and thoroughly read and understood before installing, operating or servicing this heater. This heater is intended for use with either Natural Gas or Propane Gas. It must be installed by a qualified service person or a licensed contractor in accordance with state and local codes.

▲ WARNING: Improper installation, adjustment, alteration, service, or maintenance can cause property damage, injury or death. Read the installation, operation and maintenance instructions thoroughly before installing or servicing this equipment. For assistance or additional information, consult a qualified installer, service agency or the gas supplier.

INSPECT all combustion air openings into the building and, if necessary, clear if they become blocked by dust.

FOR YOUR SAFETY: If the heater is installed without a flue, exhaust fans **MUST** be operating on an appropriate cycle when heaters are operating to avoid a high concentration of carbon monoxide. When used without fresh air, this heater may give off carbon monoxide, an odorless and poisonous gas. **CARBON MONOXIDE POISONING MAY LEAD TO DEATH.** Early signs of carbon monoxide poisoning resemble the flu with headaches, dizziness and nausea. If you experience these signs, **GET FRESH AIR IMMEDIATELY!** Have the heaters serviced as soon as possible and check the ventilation in the house.

These heaters are designed for agricultural applications and may operate with the use of either Natural Gas or Liquid Propane (LP) Gas. Check the heater's nameplate to determine the correct gas type before proceeding with installation.

!INSTALLER: This manual is the property of the owner. Please present this manual to the owner when you leave the job site.

IF YOU SMELL GAS:

- ! **DO NOT** try to light any appliance.
- ! **DO NOT** touch any electrical switch; **DO NOT** use any telephone in your building.
- ! **IMMEDIATELY** call your gas supplier from a neighbor's telephone. Follow the gas supplier's instructions. If you cannot reach your gas supplier, call the fire department.

FOR YOUR SAFETY

DO NOT store or use gasoline or other flammable vapors and liquids in the vicinity of this or any other appliance.

!IMPORTANT: SAVE THIS MANUAL FOR FUTURE REFERENCE.

Gas Fired Products (UK) Ltd.

Chapel Lane, Claydon, Ipswich, Suffolk IP6 0JL, England

Phone 01473 830551 Fax: 01473 832055 E-mail: info@spaceray.co.uk www.spaceray.com.uk

TABLE OF CONTENTS

<u>SECTION</u>	<u>DESCRIPTION</u>	<u>PAGE</u>
1.0)	Safety	2
2.0)	Installer Responsibility	2
3.0)	General Information	2
4.0)	Minimum Clearances to Combustibles.....	4
5.0)	Specifications	5
6.0)	Packing List.....	6
7.0)	Dimensions – U Tube Configurations.....	12
7.1)	Heater assembly overview – u tube configurations	14
8.0)	Dimensions – LINEAR Tube Configurations.....	18
8.1)	Heater Assembly Overview - LINEAR tube configurations	19
9.0)	Typical Suspension Methods.....	23
9.1)	Burner box support details.....	24
9.2)	User Instruction Label	25
10.0)	Typical heater assembly	25
10.1)	Tube coupling details.....	26
10.2)	Inserting Turbulators.....	25
10.3)	Attaching u-bend	27
10.4)	Attaching burner Box Assembly.....	28
10.5)	Attaching Fan Assembly	29
11.0)	Gas Connections and Regulations	29
12.0)	Instructions for Pressure Test Gauge Connection.....	31
13.0)	Electrical Connections	32
14.0)	Venting and Fresh Air for Combustion.....	35
15.0)	Lighting and Shutdown Instructions.....	40
16.0)	Commissioning.....	41
17.0)	Cleaning and Annual Maintenance	41
18.0)	Troubleshooting Guide	43
19.0)	Replacing Parts	45
19.1)	Removal of Electrodes	45
19.2)	Removing Main Burner.....	46
19.3)	Removing Injector	46
19.4)	Removing Ignition Control	47
19.5)	Removing Air Switch.....	47
19.6)	Removing Gas Valve and Manifold Assembly	48
19.7)	Removing Neon Indicator	48
19.8)	Removing Air Inlet Plate	49
19.9)	Removing the Fan.....	49
20.0)	Conversion Instructions.....	50
21.0)	Installation Data.....	50
22.0)	Replacement Parts Guide.....	51

1.0) SAFETY

This heater is a self-contained infrared radiant tube heater. Safety information required during installation and operation of this heater is provided in this manual and the labels on the product. The installation, service and maintenance of this heater must be performed by a contractor qualified in the installation and service of gas fired heating equipment.

All personnel in contact with the heater must read and understand all safety information, instructions and labels before operation. The following symbols will be used in this manual to indicate important safety information.



Warning instructions must be followed to prevent or avoid hazards which may cause serious injury, property damage or death.



Caution instructions must be followed to prevent incorrect operation or installation of the heater which may cause minor injury or property damage.

2.0) INSTALLER RESPONSIBILITY

The installer is responsible for the following:

- The heater and venting, as well as electrical and gas supplies must be installed in accordance with these installation instructions and any applicable codes and regulations.
- Every heater shall be located with respect to building construction and other equipment so as to permit access to the heater.
- Each installer must follow the clearances to combustible materials for the heaters.
- Install the heater so that the supports and hangers are correctly spaced in accordance with these instructions. The heater must be supported by materials having a working load limit of at least 52kg.
- Supply the owner with a copy of these Installation and Operation Instructions.
- Never use the heater as a support for a ladder or other access equipment. Do not hang anything from the heater.
- Supply all installation materials necessary that are not included with the heater.
- Check the nameplate to make sure that the burner is correct for the gas type in the building.

3.0) GENERAL INFORMATION

This heater is a self-contained infrared radiant tube heater designed for use where flammable gases or vapors are not generally present.

Installation of this heater must be in accordance with all applicable codes shown in the instructions and/or the local codes and authorities having jurisdiction. In the UK all equipment must be installed and maintained in accordance with the relevant provisions of the Gas Safety (Installations and Use) Regulations 1998 for gas fired products. Installation practices must take into account the Health and Safety at Works Act 1974 or relevant codes of practice. In addition the installation must be carried out in accordance with the current IEE wiring regulations (BS 7671:2001), BS 6896:2005 (Industrial & Commercial) and any other relevant British Standards and Codes of Practice by a qualified installer. All external wiring **MUST** comply with the current IEE wiring regulations.

Clearances to combustibles as outlined in the manual should always be observed. In areas used for storage of combustible materials where they may be stacked below the heater, the installer must post signs that will "specify the maximum permissible stacking height to maintain the required clearances from the heater to combustibles."

Every heater shall be located with respect to building construction and other equipment so as to permit access to the control housing. Each installer shall use skillful and reliable installation practices when locating the heaters and must give consideration to service accessibility.

This heater is for **INDOOR INSTALLATION ONLY** and is used in **VENTED or UNVENTED** mode. The term *Unvented* actually means *Indirect Vented*. While the products of combustion are expelled into the building, national codes require ventilation in the building to dilute these products of combustion. This ventilation must be provided by gravity or mechanical means. Ventilation requirements are addressed further in these instructions.

Although these heaters may be used in many applications other than space heating (e.g., process heating), Space-Ray will not recognize the warranty for any use other than space heating.

This heater is not an explosion proof heater. Where the possibility of exposure to volatile and low flash point materials exists, it could result in property damage or death. This heater must not be installed in a spray booth where the heater can operate during the spraying process. Consult your local fire marshal or insurance company.

Linear Configuration Series Only: Since linear configuration tube heaters are always hotter at the control end than at the flue terminal end, always observe the minimum recommended mounting heights.

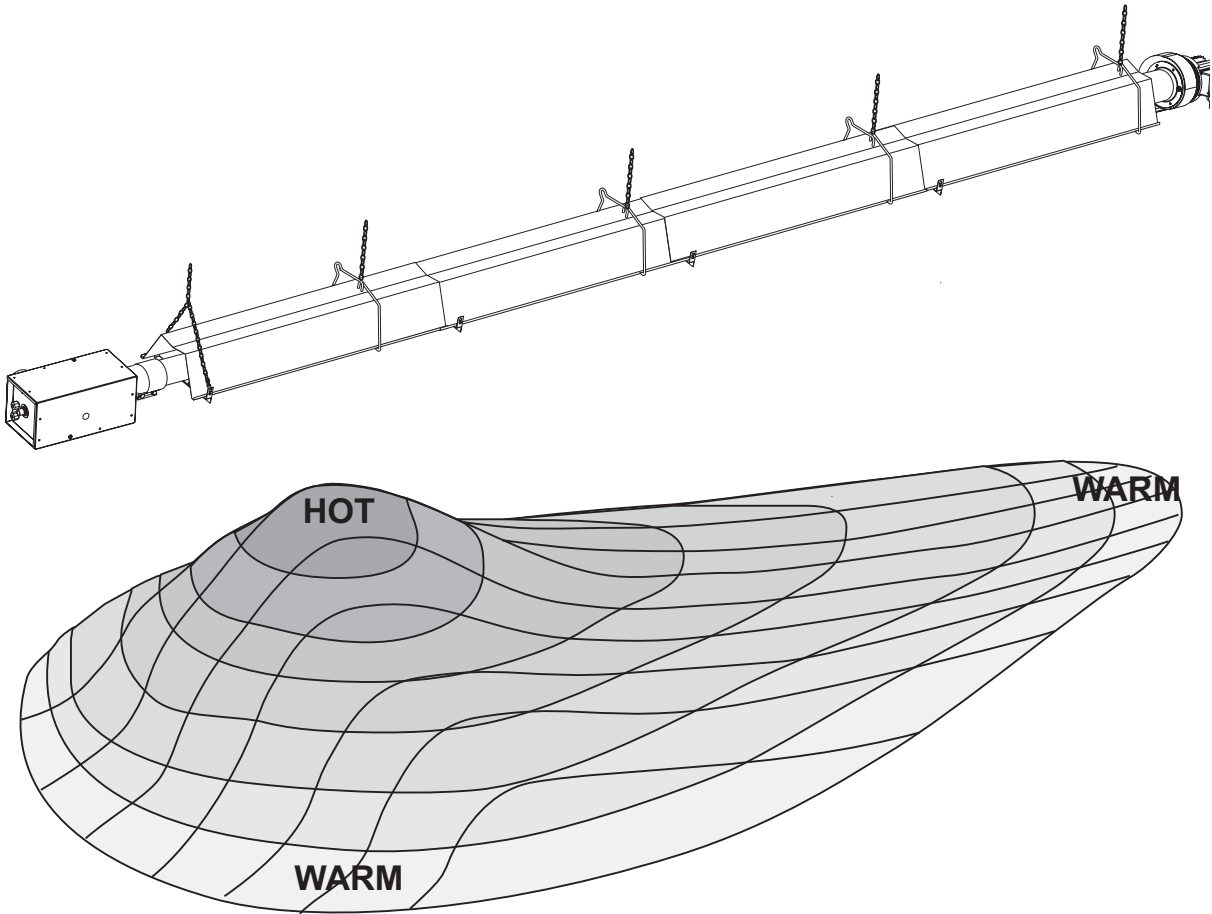

Fig. 1

4.0) MINIMUM CLEARANCES TO COMBUSTIBLES

⚠ WARNING		
		FIRE AND EXPLOSION HAZARD Combustible material must be located outside the clearance dimensions listed. Failure to do so may result in death, serious injury or property damage.

Minimum clearances to combustibles shall be measured from the outer surfaces as shown in the following diagram:

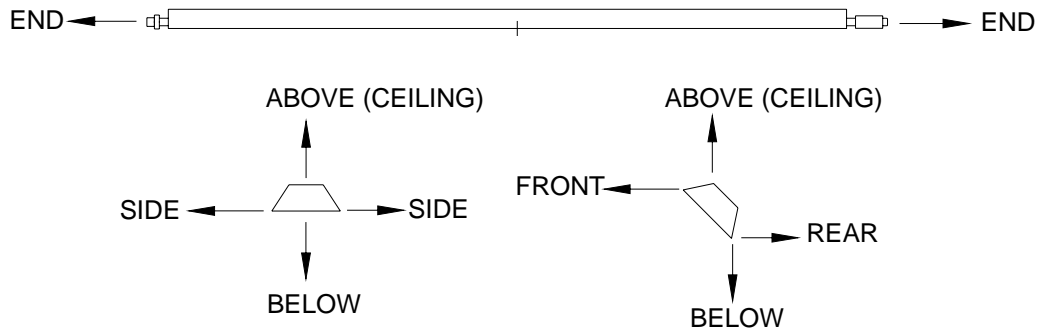

Fig. 2

Table 1

MINIMUM CLEARANCES TO COMBUSTIBLES						
	Side	Above	Below	End	Front	Rear
CBU09-15, SRL09-15	450mm	450mm	1220mm	450mm	575mm	305mm
SRU25, ERU25, SRL25	510mm	450mm	1220mm	510mm	610mm	305mm
SRU30-45, SRL30-45	760mm	610mm	2285mm	610mm	760mm	380mm

▲ WARNING: Certain materials or objects, when stored under the heater, will be subjected to radiant heat and could be seriously damaged. Observe the Minimum Clearances to Combustibles listed in the manual and on the heater at all times.

NOTE:

1. The clearances specified above must be maintained to combustibles and other materials that may be damaged by temperatures 50°C above ambient temperature. Clearances to combustibles are posted on the control box. In areas used for storage of combustible materials where they may be stacked below the heater, NFPA54 requires that the installer must post signs that will “specify the maximum permissible stacking height to maintain the required clearances from the heater to combustibles.” Space-Ray recommends posting these signs adjacent to the heater thermostat or other suitable location that will provide enhanced visibility.

2. The stated clearance to combustibles represents a surface temperature of 50 °C above room temperature. Building materials with a low heat tolerance (such as plastics, vinyl siding, canvas, tri-ply, etc.) may be subject to degradation at lower temperatures. It is the installer’s responsibility to assure that adjacent materials are protected from degradation.

5.0) SPECIFICATIONS

Table 2

MODEL	CBU09/SRL09-N	CBU09/SRL09-L
Heat Input	9.0 kW Hs 8.1 kW Hi	
Appliance Type (II _{2H3P})	A2, B ₂₂ , C ₁₂ , C ₃₂ , C ₅₂	
Appliance Category	II _{2H3P}	
Adjusted for	2H G20 20mbar	3P G31 37mbar
Setting Pressure	12.5mbar	25mbar
Injector	Ø2.4mm	Ø1.6mm
Burner Baffle Plate	PN 4260360P	PN 4260360P
Electrical Supply	230V~50Hz 125W	
Fuse Externally	3A	
Dimensions	CBU 09 3.10m x 0.46m	SRL 09 5.493m x 0.34m
Weight	CBU 09 31kg	SRL 09 27kg
Gas Connection	R - ½	
Flue Size	Ø100mm	

Table 3

MODEL	CBU12/SRL12-N	CBU12/SRL12-L
Heat Input	11.4 kW Hs 10.3 kW Hi	
Appliance Type (II _{2H3P})	A2, B ₂₂ , C ₁₂ , C ₃₂ , C ₅₂	
Appliance Category	II _{2H3P}	
Adjusted for	2H G20 20mbar	3P G31 37mbar
Setting Pressure	12.5mbar	25mbar
Injector	No. 36	Ø1.8mm
Burner Baffle Plate	PN 4260360Q	PN 4260360Q
Electrical Supply	230V~50Hz 125W	
Fuse Externally	3A	
Dimensions	CBU 12 3.10m x 0.46m	SRL 12 5.493m x 0.34m
Weight	CBU 12 31kg	SRL 12 27 kg
Gas Connection	R - ½	
Flue Size	Ø100mm	

Table 4

MODEL	CBU15/SRL15-N	CBU15/SRL15-L
Heat Input	15. kW Hs 13.5 kW Hi	
Appliance Type	A2, B ₂₂ , C ₅₂	
Appliance Category	II _{2H3P}	
Adjusted for	2H G20 20mbar	3P G31 37mbar
Setting Pressure	12.5mbar	25mbar
Injector	No. 31	No. 45
Burner Baffle Plate	PN 4260360A	PN 4260360A
Electrical Supply	230V~50Hz 125W	
Fuse Externally	3A	
Dimensions	CBU 15 3.10m x 0.465m	SRL 15 5.493m x 0.34m
Weight	CBU 15 31kg	SRL 15 27kg
Gas Connection	R - ½	
Flue Size	Ø100mm	

Table 5

MODEL	SRU25/SRL25/ERU25-N	SRU25/SRL25/ERU25-L
Heat Input	23.0 kW Hs 20.7 kW Hi	
Appliance Type (II _{2H3P})	A2, B ₂₂ , C ₁₂ , C ₃₂ , C ₅₂	
Appliance Category	II _{2H3P}	
Adjusted for	2H G20 20mbar	3P G31 37mbar
Setting Pressure	12.5mbar	25mbar
Injector	Ø3.8mm	No. 39
Burner Baffle Plate	PN 4260360D	PN 4260360D
Electrical Supply	230V~50Hz 125W	
Fuse Externally	3A	
Dimensions	SRU25/ERU25: 5.385m x 0.465m	SRL25: 10.065m x 0.34m
Weight	SRU25: 47kg ERU25: 47kg	SRL25: 46kg
Gas Connection	R - ½	
Flue Size	Ø100mm	

Table 6

MODEL	SRU30/SRL30-N	SRU30/SRL30-L
Heat Input	29.2 kW Hs 26.3 kW Hi	
Appliance Type (II _{2H3P})	A2, B ₂₂ , C ₁₂ , C ₃₂ , C ₅₂	
Appliance Category	II _{2H3P}	
Adjusted for	2H G20 20mbar	3P G31 37mbar
Setting Pressure	12.5mbar	25mbar
Injector	No. 19	No. 34
Burner Baffle Plate	PN 4260360E	PN 4260360E
Electrical Supply	230V~50Hz 125W	
Fuse Externally	3A	
Dimensions	SRU30: 5.51m x 0.715m	SRL30: 9.955m x 0.34m
Weight	SRU30: 66kg	SRL30: 62kg
Gas Connection	R - ½	
Flue Size	Ø100mm	

Table 7

MODEL	SRU35/SRL35-N	SRU35/SRL35-L
Heat Input	34.5 kW Hs 31.1 kW Hi	
Appliance Type (II _{2H3P})	A2, B ₂₂ , C ₁₂ , C ₃₂ , C ₅₂	
Appliance Category	II _{2H3P}	
Adjusted for	2H G20 20mbar	3P G31 37mbar
Setting Pressure	12.5mbar	25mbar
Injector	No. 15	Ø3.1mm
Burner Baffle Plate	PN 4260360F	PN 4260360F
Electrical Supply	230V~50Hz 125W	
Fuse Externally	3A	
Dimensions	SRU35: 5.51m x 0.715m	SRL35: 9.955m x 0.34m
Weight	SRU35: 66kg	SRL35: 62kg
Gas Connection	R - ½	
Flue Size	Ø100mm	

Table 8

MODEL	SRU40/SRL40-N	SRU40/SRL40-L
Heat Input	42.2kW Hs 38.0kW Hi	
Appliance Type (II _{2H3P})	A2, B ₂₂ , C ₁₂ , C ₃₂ , C ₅₂	
Appliance Category	II _{2H3P}	
Adjusted for	2H G20 20mbar	3P G31 37mbar
Setting Pressure	12.5mbar	25mbar
Injector	Ø 5.0mm	Ø 3.3mm
Burner Baffle Plate	PN 4260360G	PN 4260360G
Electrical Supply	230V~50Hz 125W	
Fuse Externally	3A	
Dimensions	SRU40: 6.97m x 0.715m	SRL40: 13.00m x 0.34m
Weight	SRU40: 81kg	SRL40: 79kg
Gas Connection	R - ½	
Flue Size	Ø100mm	

Table 9

MODEL	SRU45/SRL45-N	SRU45/SRL45-L
Heat Input	47.0 Kw Hs 42.3 Kw Hi	
Appliance Type (II _{2H3P})	A2, B ₂₂ , C ₁₂ , C ₃₂ , C ₅₂	
Appliance Category	II _{2H3P}	
Adjusted for	2H G20 20mbar	3P G31 37mbar
Setting Pressure	12.5mbar	25mbar
Injector	Ø 5.4mm	No. 28
Burner Baffle Plate	PN 4260360H	PN 4260360H
Electrical Supply	230V~50Hz 125W	
Fuse Externally	3A	
Dimensions	SRU45: 6.97m x 0.715m	SRL45: 13.00m x 0.34m
Weight	SRU45: 81kg	SRL45: 79kg
Gas Connection	R - ½	
Flue Size	Ø100mm	

6.0) Packing List

6.1 CBU09/12/15 SRU25/ERU25

The appliances are supplied as follows:-

Table 10

REF	PART NO.	MODEL	CBU09/12/15	SRU/ERU25
		Carton (containing the following)	1	1
1		Fastenings Pack	1	1
2		Burner Box Assembly	1	1
3	4260021	Fan Assembly	1	1
4	4260372	U-Bend	1	1
5	4260372	Hanger Bracket	2	3
6	4267923	Torctite Coupling	2	2
7	4260020	Radiant Tube (Ø 76.2 x 4572)	-	2
8	4250636	Radiant Tube (Ø 76.2 x 2285)	2	-
9	4260375	Reflector Panel (2438 long)	1	2
9	4260384	Reflector End Panel (notched)	1	1
10	4260383	Reflector End Panel (plain)	1	1

CBU09/12/15

Fig. 3

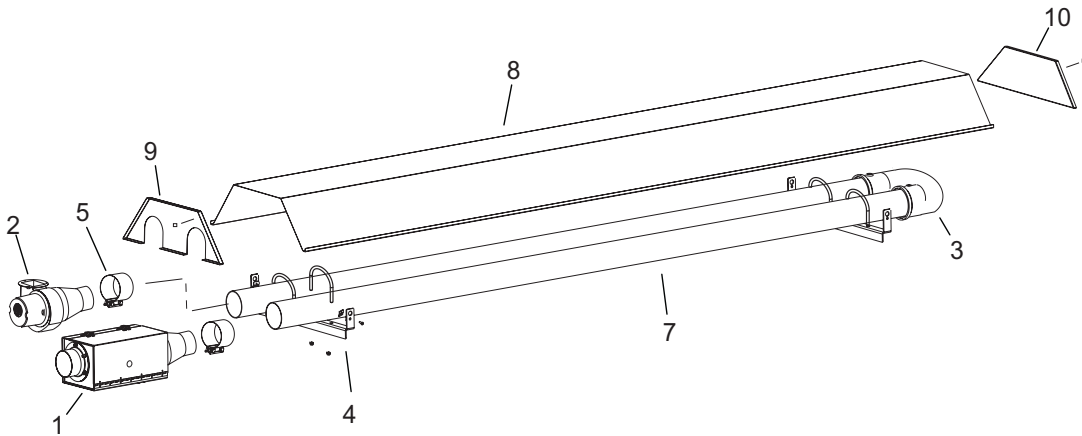

SRU/ERU25

Fig. 3a

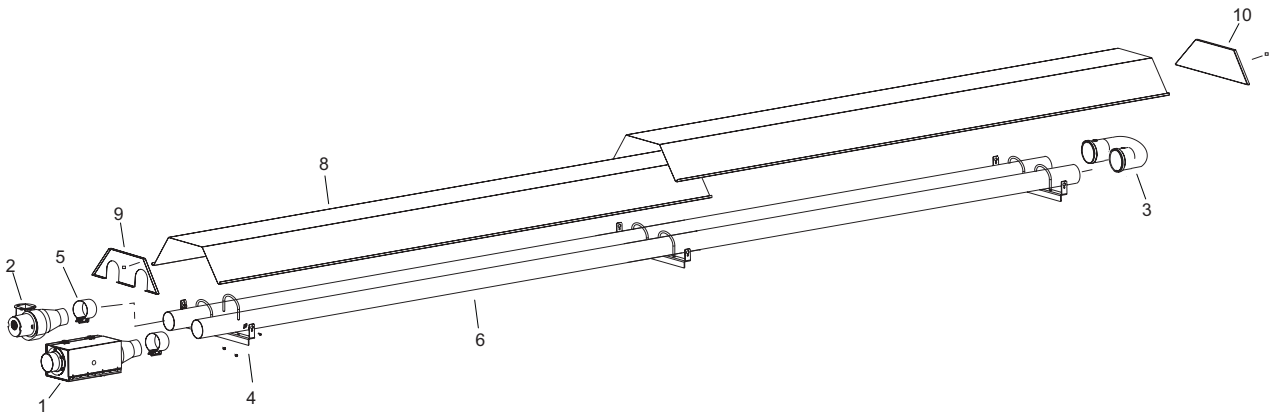

**6.2 SRU30/35
SRU40/45**

The appliances are supplied as follows:-

Table 11

REF	PART NO.	MODEL	SRU30	SRU35	SRU40	SRU45
		Carton (containing the following)	1	1	1	1
		Fastenings Pack	1	1	1	1
1		Burner Box Assembly	1	1	1	1
2		Fan Assembly	1	1	1	1
3	4260374	U-Bend	1	1	1	1
4	4260373	Hanger Brackets	3	3	4	4
5	4267924	Torctite Coupling	4	4	4	4
6	4250638	Radiant Tube (Ø 101.6 x 3048)	2	2	4	4
7	4250637	Radiant Tube (Ø 101.6 x 1524)	2	2	-	-
8	4260376	Reflector Panel (2540 long)	2	2	2	2
9	4260377	Reflector Panel (1511 long)	-	-	1	1
10	4260388	Reflector End Panel (notched)	1	1	1	1
11	4260387	Reflector End Panel (plain)	1	1	1	1

SRU30/35 Fig. 4

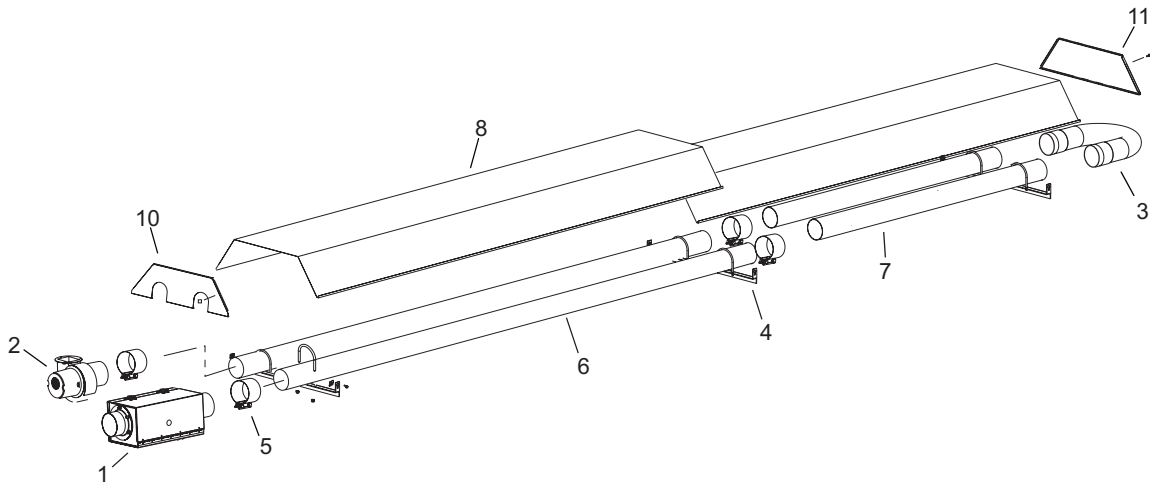

SRU40/45 Fig. 5

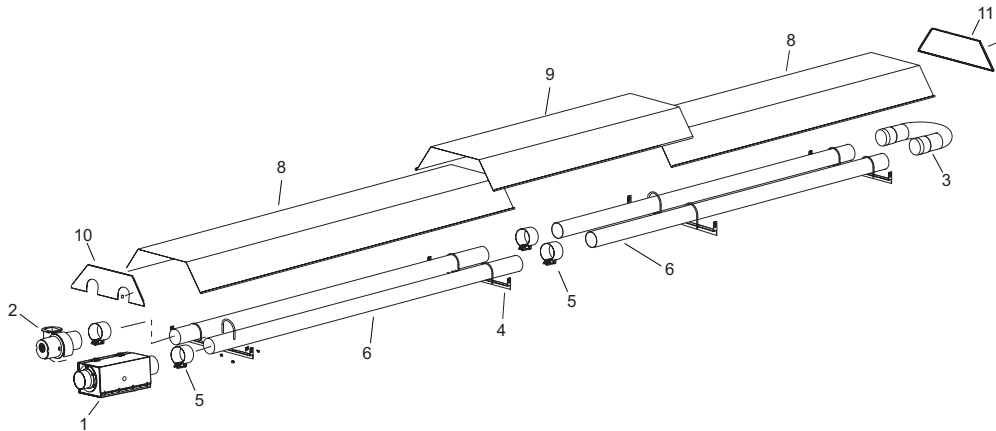

**6.3 SRL09/12/15
SRL25**

The appliances are supplied as follows:-

Table 12

REF	PART NO.	MODEL	SRL09/12/15	SRL25
		Carton (containing the following)	1	1
1		Fastenings Pack	1	1
2		Burner Box Assembly	1	1
3	4260245	Fan Assembly	1	1
4	4267923	Hanger Brackets	3	4
5	4260020	Torcite Coupling	2	3
6	4260020	Radiant Tube (Ø 76.2 x 4572)	1	2
7	4260175	Reflector Panel (1511 long)	1	-
8	4260176	Reflector Panel (3035 long)	1	3
	4260244	Reflector End Panel	2	2

SRL09/12/15 Fig. 6

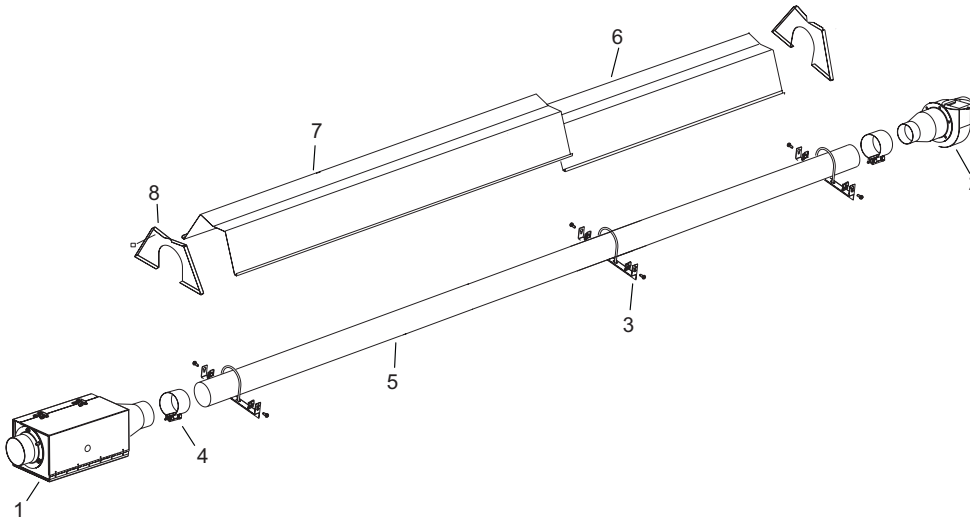

SRL25 Fig. 6a

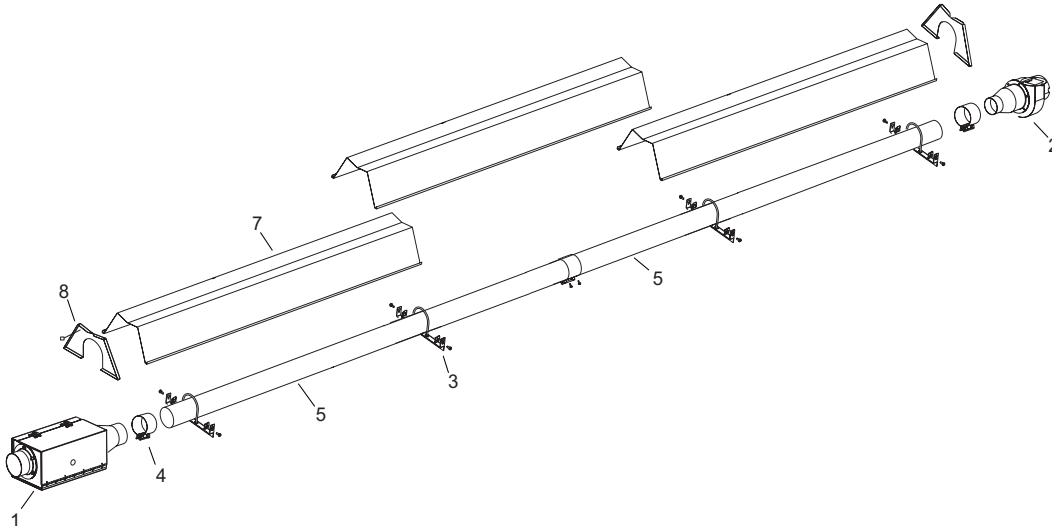

**6.4 SRL30/35
SRL40/45**

The appliances are supplied as follows:-

Table 13

REF	PART NO.	MODEL	SRL30	SRL35	SRL40	SRL45
		Carton (containing the following)	1	1	1	1
		Fastenings Pack	1	1	1	1
1		Burner Box Assembly	1	1	1	1
2		Fan Assembly	1	1	1	1
3	4260245	Hanger Brackets	4	4	5	5
4	4267924	Torctite Coupling	4	4	5	5
5	4250638	Radiant Tube (Ø 101.6 x 3048)	3	3	4	4
6	4260142	Turbulator (3048mm) in tube	1	1	1	1
7	4260174	Reflector Panel (3035 long)	3	3	4	4
8	4260244	Reflector End Panel	2	2	2	2

SRL30/35 Fig. 7

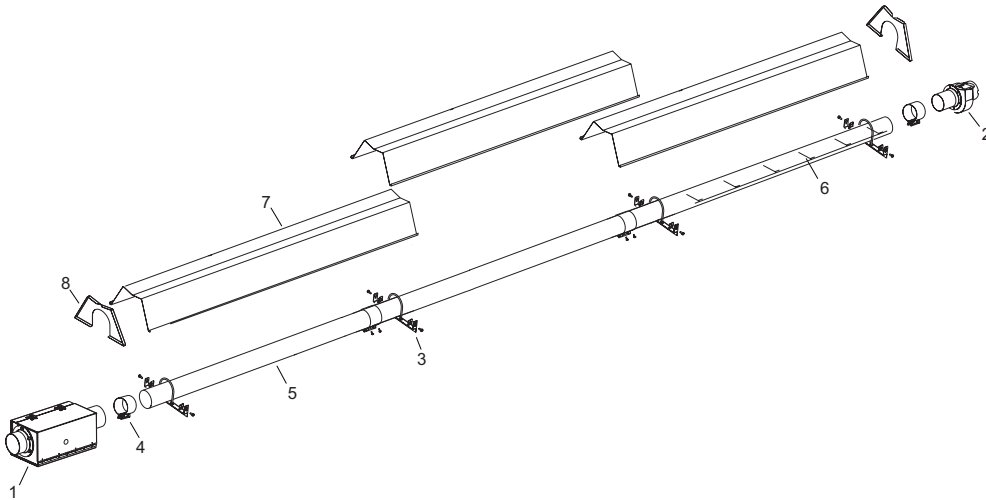

SRL40/45 Fig. 8

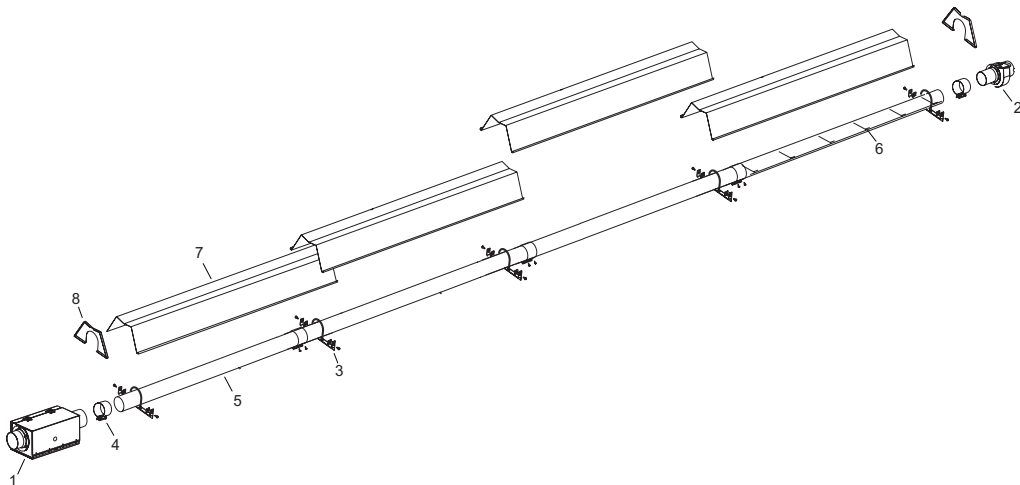

7.0) DIMENSIONS - U TUBE CONFIGURATIONS

Fig. 9

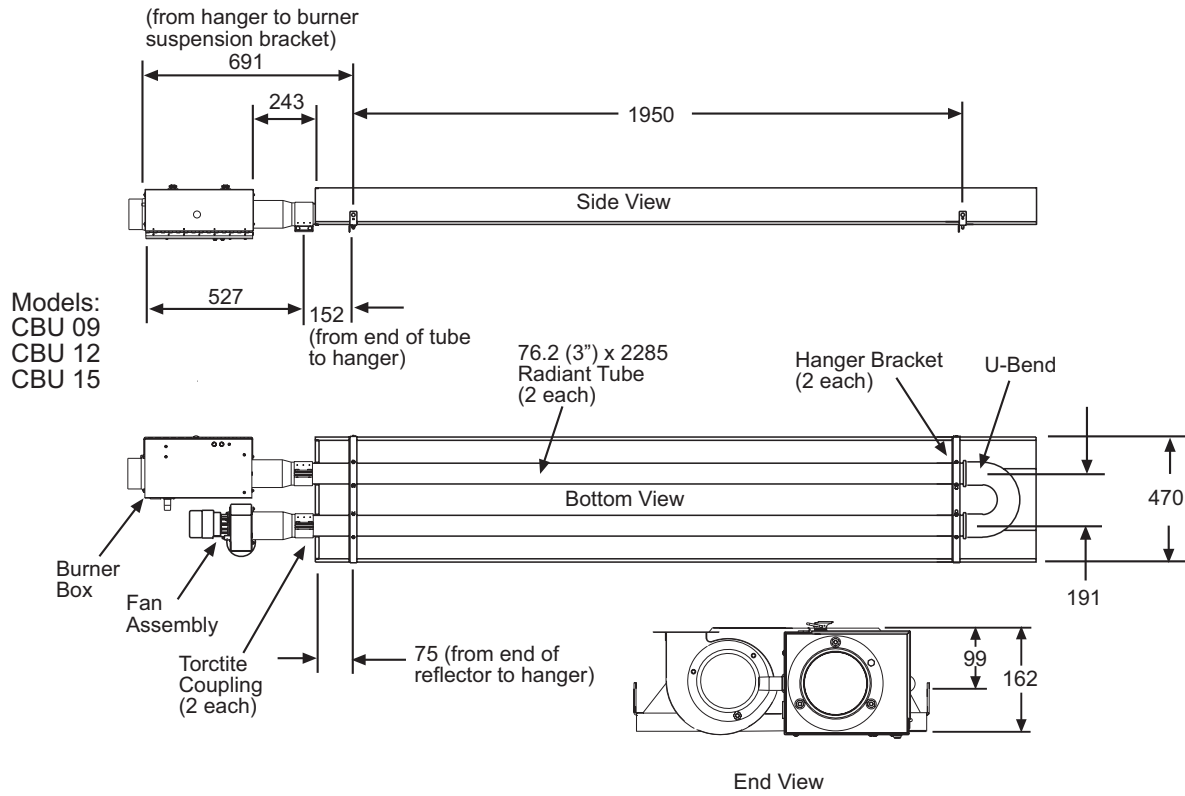

Fig. 9a

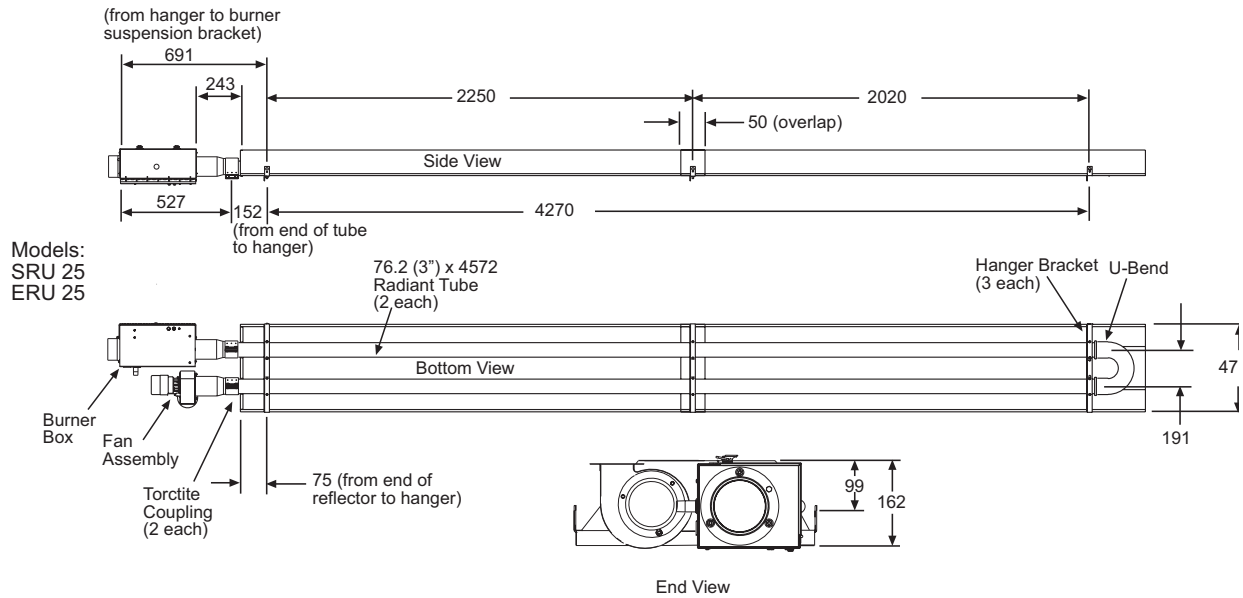

Fig. 10

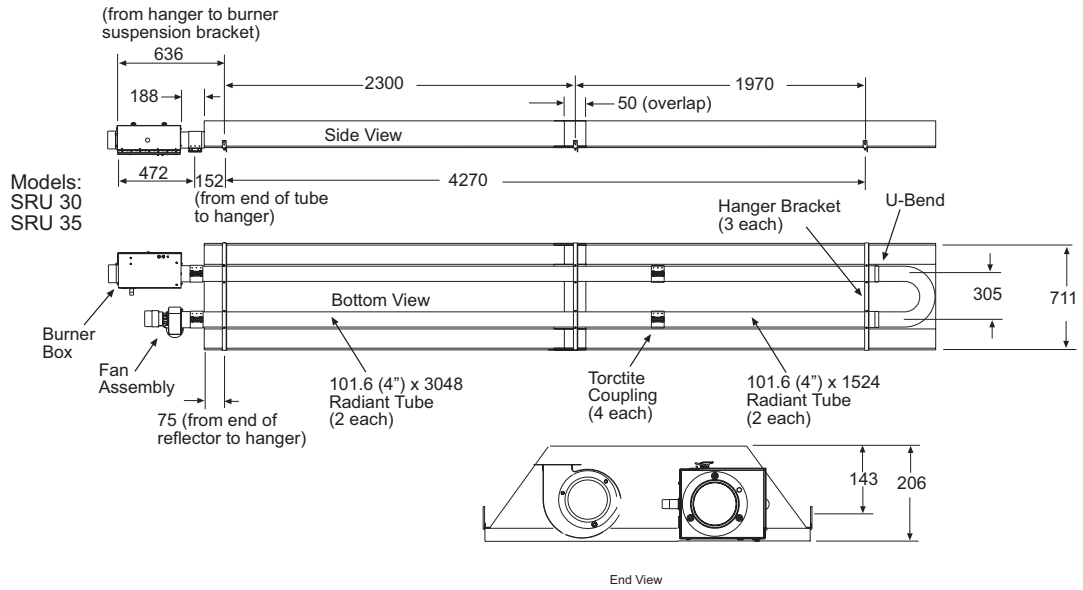
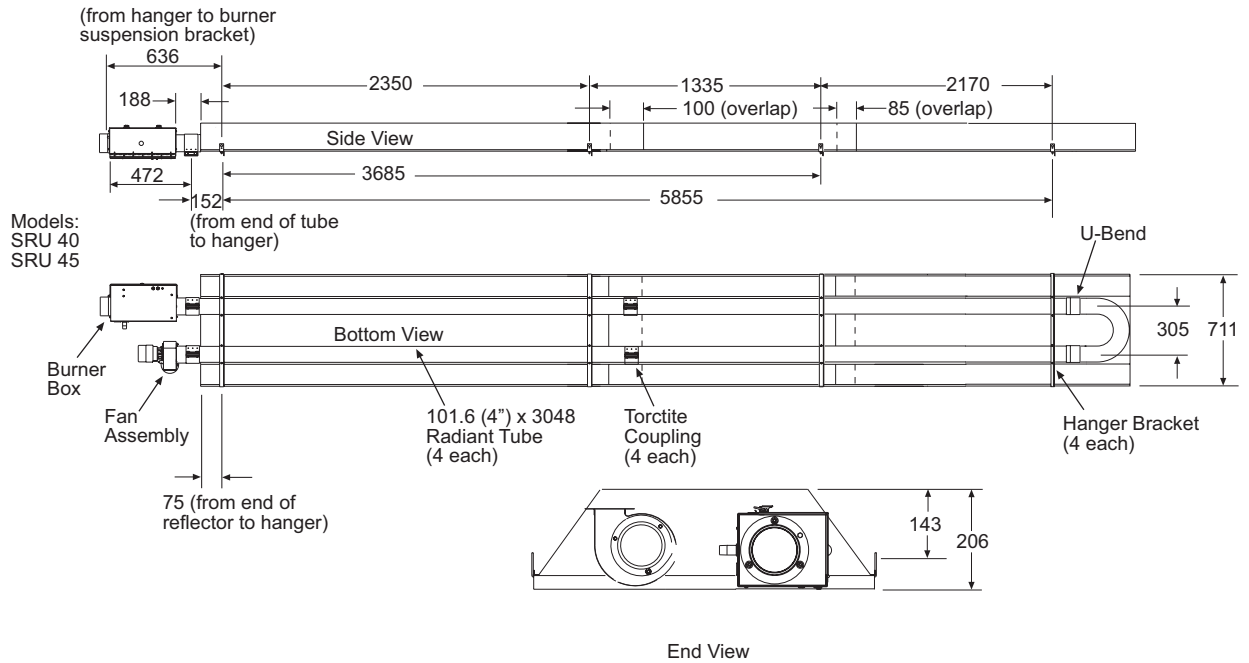

Fig. 11



7.1) HEATER ASSEMBLY OVERVIEW - U TUBE CONFIGURATIONS

Fig. 12

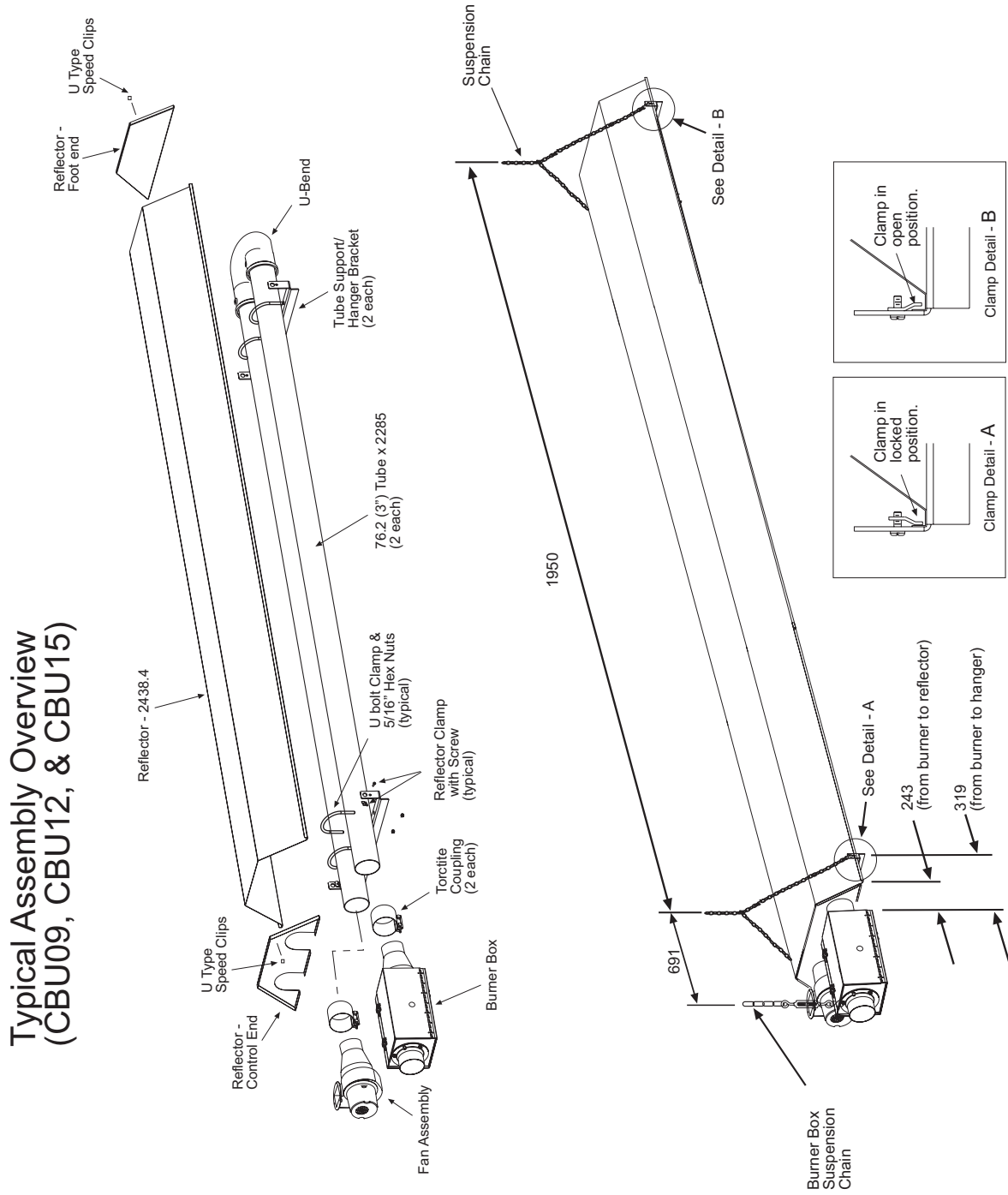
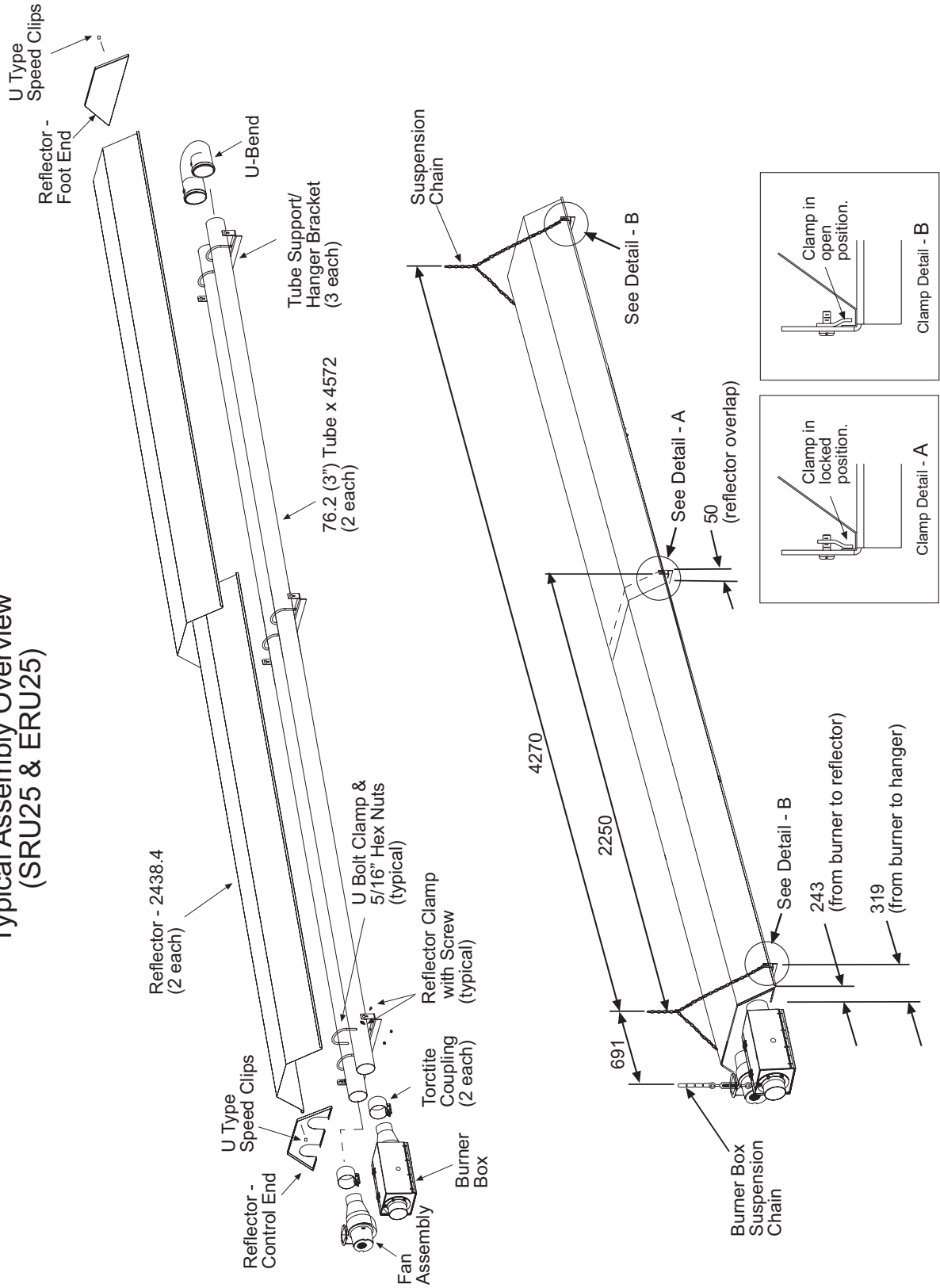

Fig. 12a

Typical Assembly Overview
(SRU25 & ERU25)



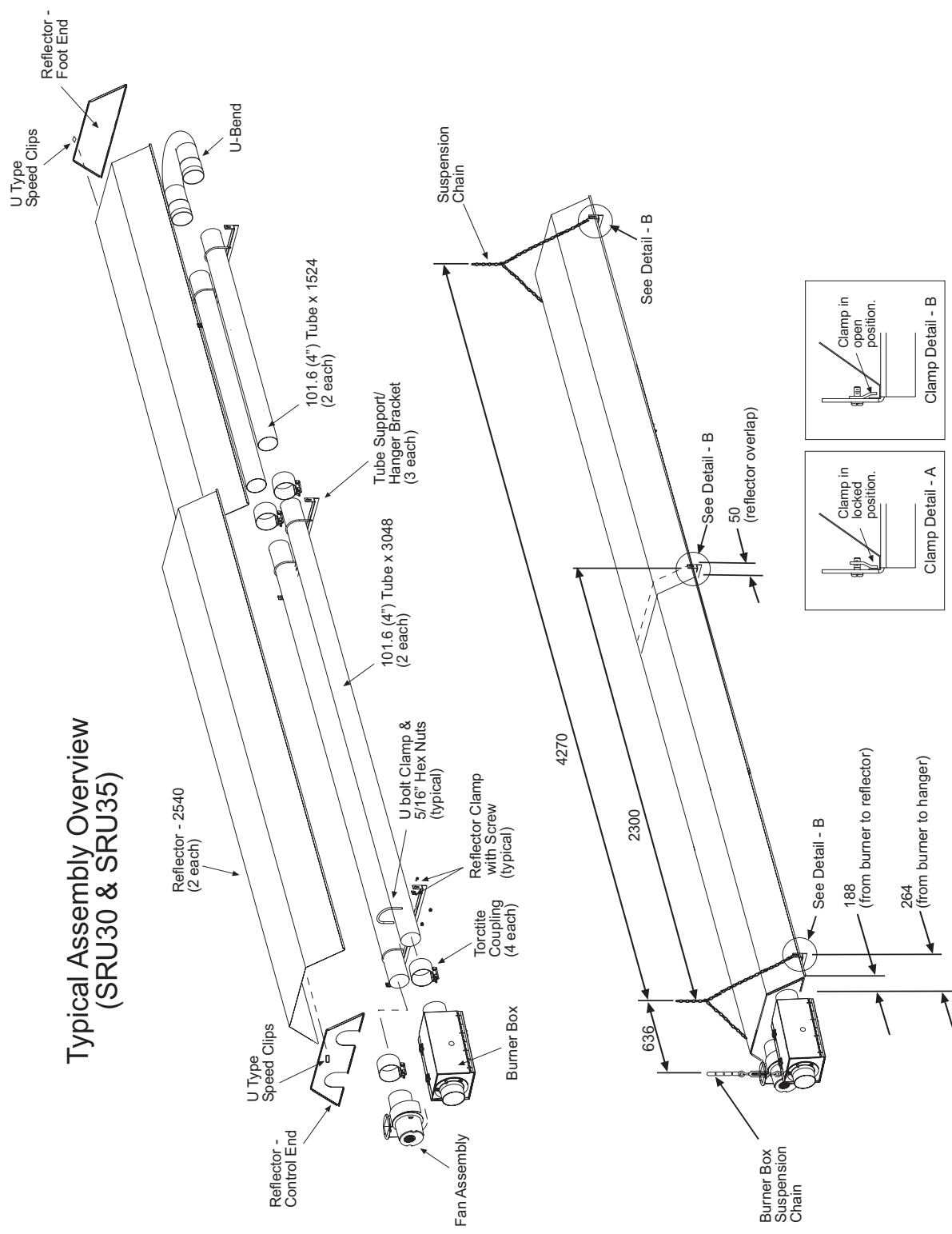

Fig. 13

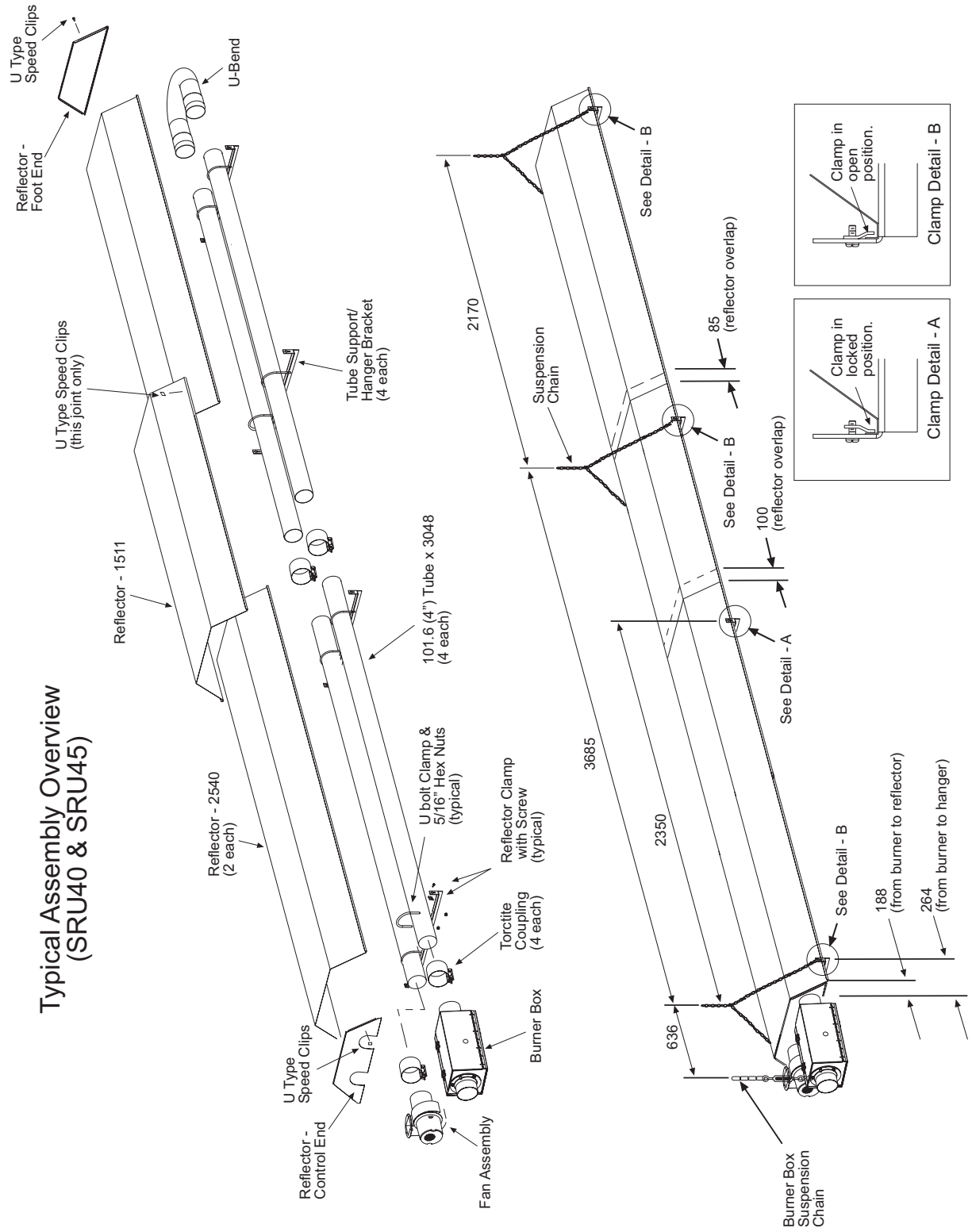

Fig. 14

8.0) DIMENSIONS - LINEAR TUBE CONFIGURATIONS

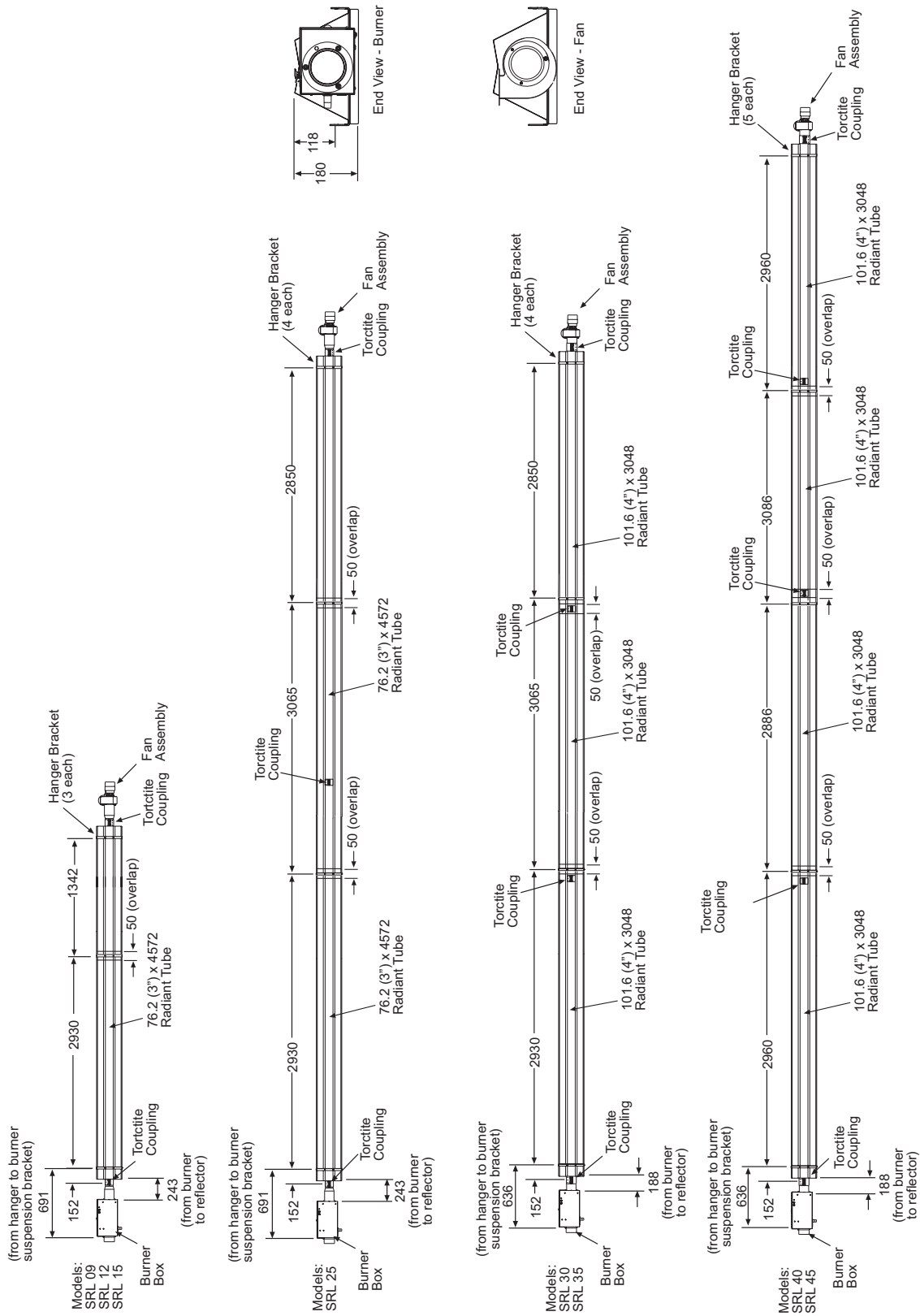

Fig. 15

8.1) HEATER ASSEMBLY OVERVIEW - LINEAR TUBE CONFIGURATIONS

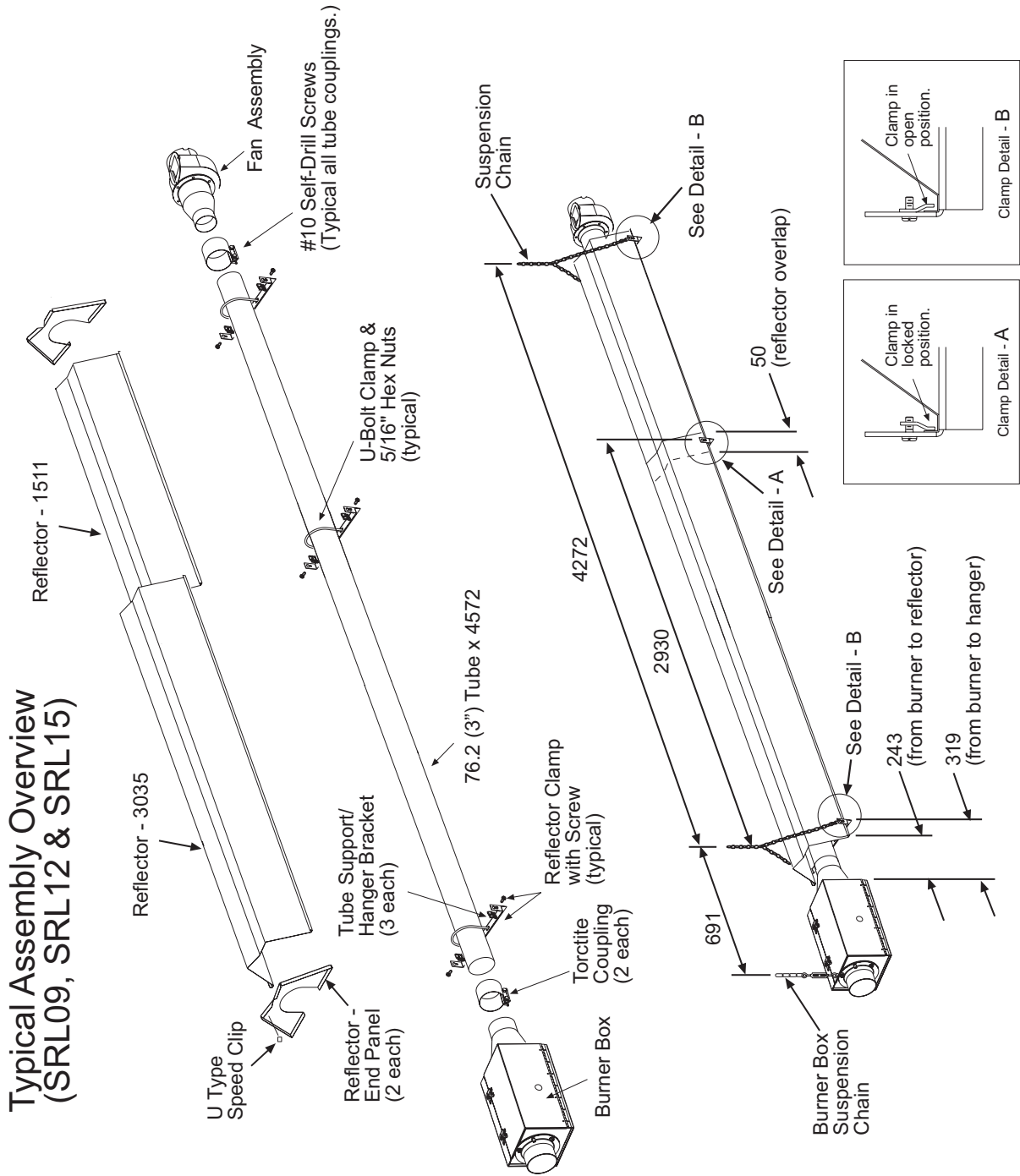

Fig. 16

Typical Assembly Overview (SRL25)

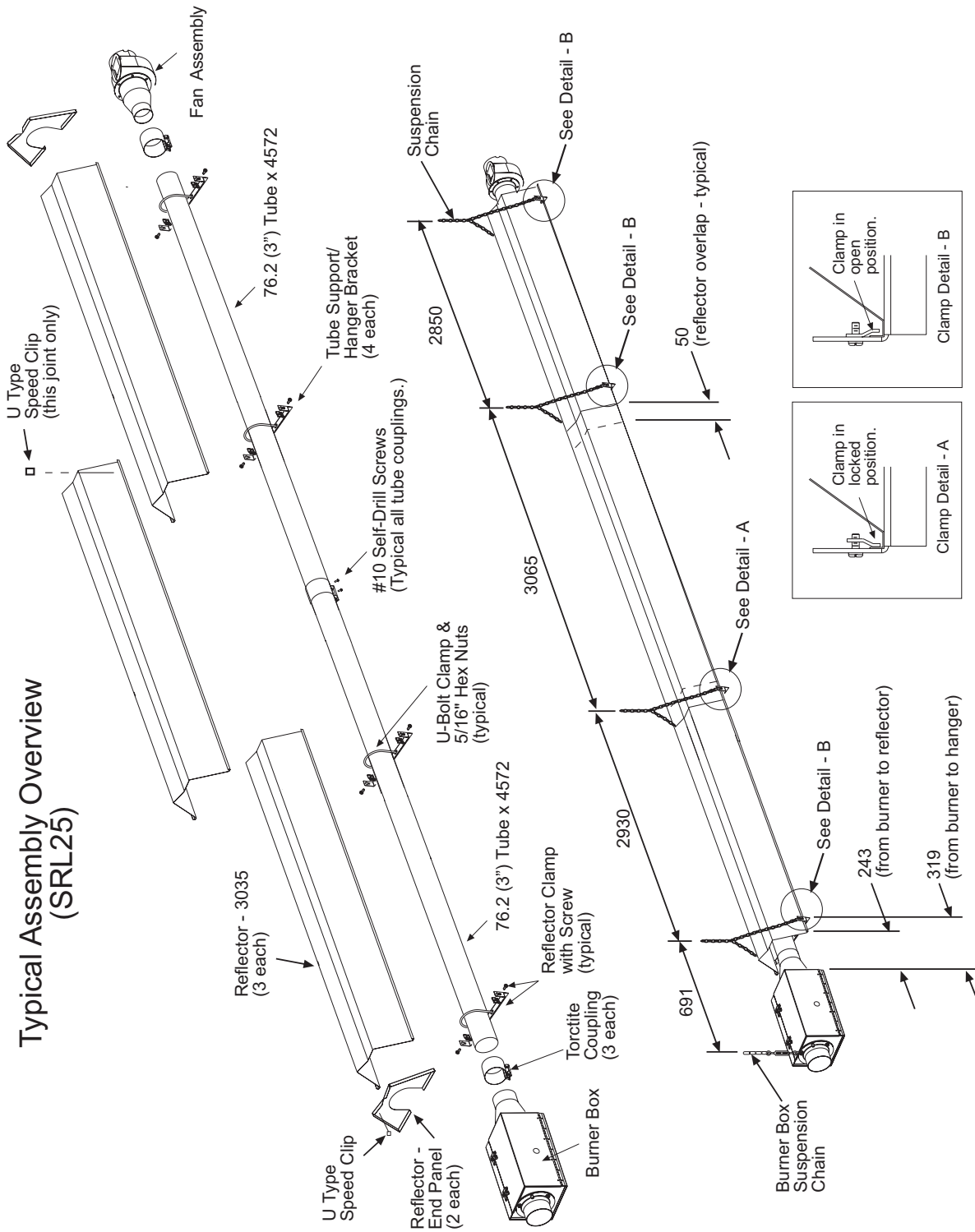

Fig. 16a

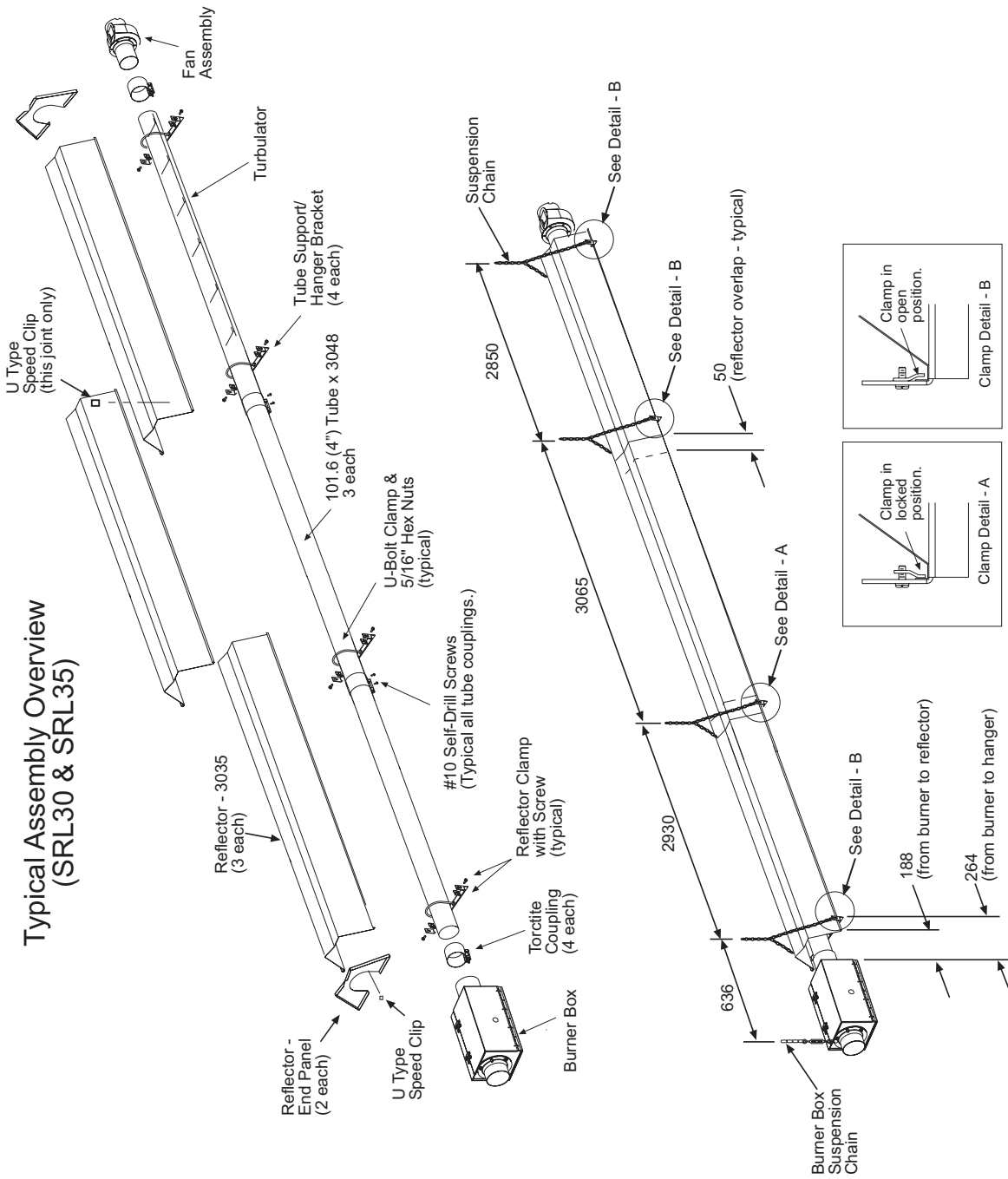

Fig 17

Typical Assembly Overview (SRL40 & SRL45)

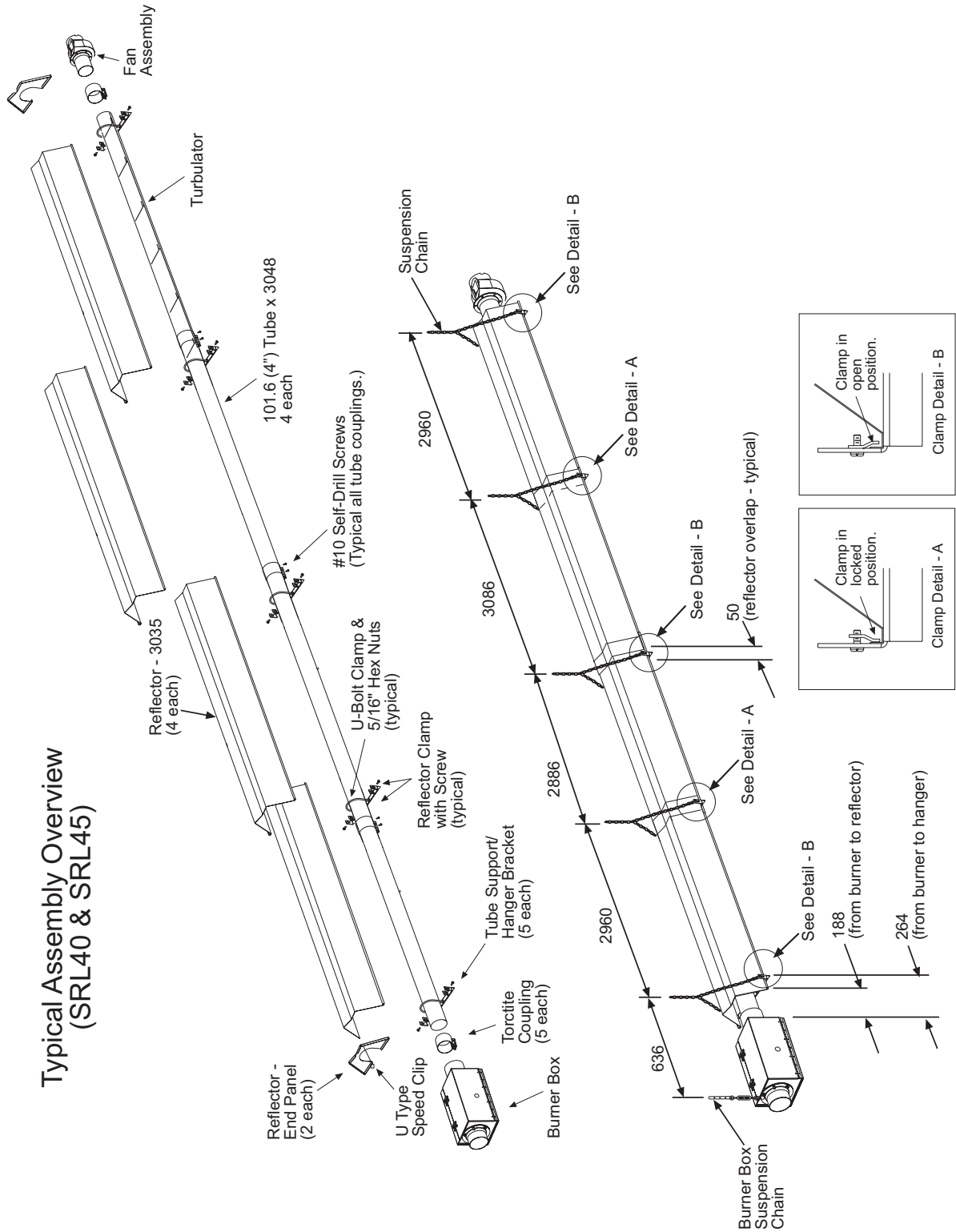



Fig. 17a

9.0) TYPICAL SUSPENSION METHODS

Notwithstanding their limited scope, the appliance should be installed in accordance with the relevant provisions of any National Gas Safety (Installation and Use) Regulations. Due account should also be taken of any obligations arising from any National Health and Safety at Work Regulations, National and Local Building Regulations and National Electrical Wiring Regulations. The appliance must be installed, and where necessary, converted for use on other gases, by a qualified installer.

⚠ WARNING	
	SUSPENSION HAZARD
	<p>Burner must be secured to the mounting flange with nuts.</p> <p>All materials used to suspend the heater must have a minimum working load of 52kg.</p> <p>All "S" Hooks must be crimped closed.</p> <p>Never use the heater to support a ladder or other access equipment.</p> <p>Failure to do so may result in death, serious injury or property damage.</p>

Various means of suspending the heater can be used. See the following drawings for typical examples.

- a. Use only noncombustible materials for suspending hangers and brackets.
- b. **Linear Tube Heaters** should be suspended to provide a slope of 0.25 degree **up** to the fan (25 to 50mm). The appliance should be located with respect to building construction and other equipment to permit access to the appliance for servicing etc.
- c. **U-Tube Heaters** should be suspended horizontally along the length.
- d. Turnbuckles can be used with chains to allow leveling of the heater. All "S" hooks and eye bolts must be manually crimped closed by the installer.
- e. For suspending the appliance it is recommended that suitable protected welded chain (\varnothing 3mm x 65 links per m) or \varnothing 8mm min mild steel drop rods and suitable brackets are used. Attach the chains or drop rods to the hanger brackets where shown providing at least \varnothing 5mm closed link hooks are used chains may be attached directly to the hanger brackets.
- f. Heaters subject to vibration must be provided with vibration isolating hangers.
- g. Heaters must not be supported by gas or electric supply lines and must be suspended from a permanent structure with adequate load capacity.
- h. Hanging points are fixed along the length of heater to accommodate trim pieces. Secondary steel work may be required to span between supporting beams.
- i. The appliance should be located with respect to building construction and other equipment to permit access to the appliance for servicing etc.

Space-Ray recommends that the body sections be suspended using chains with turnbuckles. This will allow slight adjustments after assembly and heater expansion/ contraction during operation.

If a "trapeze" method is used for tube support/hanger brackets (shown below), the minimum chain length for the two connecting chains is 914 mm to minimize any vibration that might be generated by the draft inducer assembly. If these chains must be less than 914 mm, then do not use the trapeze method and, instead, use individual chains on each tube support/hanger bracket.

IMPORTANT: When **U-Tube Heaters** are angle mounted (see Fig 18) the fan should be assembled to the higher of the two emitter tubes as shown.

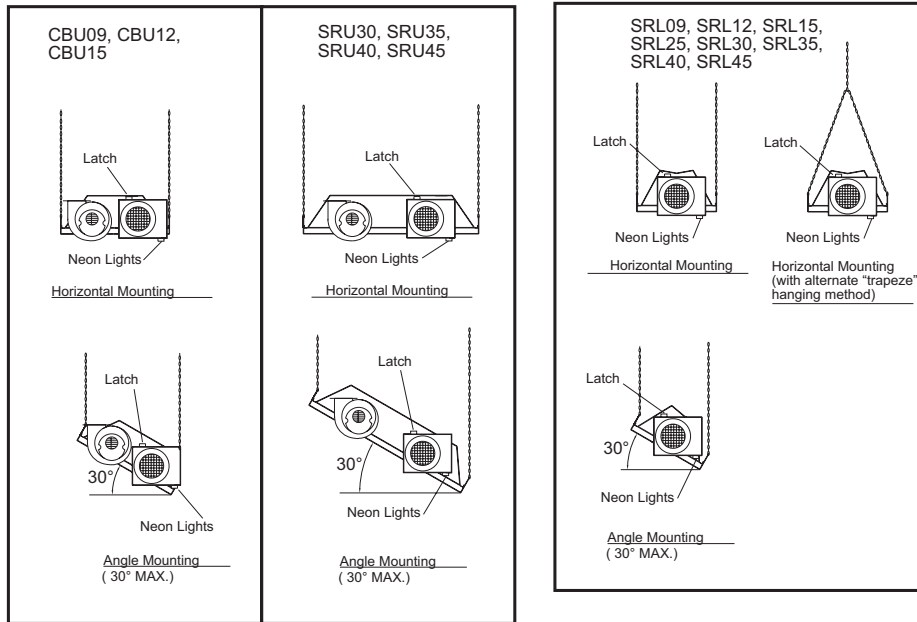
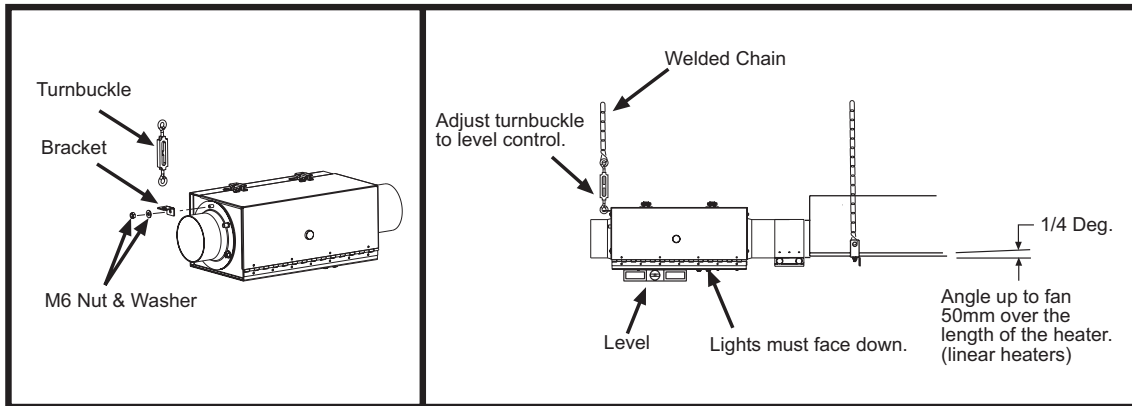

Fig. 18

9.1) BURNER BOX SUPPORT DETAILS

- The burner box must be supported with a welded chain after overall heater suspension is complete. This is to prevent burner from sagging which may cause the tube to burn tube out prematurely. Assemble bracket and turnbuckle to inlet end of burner as shown.

Fig. 19



- Adjust the turnbuckle until control box is level. Use a leveling device to verify.

! CAUTION

Failure to install the burner box suspension chain vertically will void the manufacturers warranty.

! CAUTION

Linear heaters must be angled up from the burner box. Failure to do so may result in overheating of internal components resulting in equipment failure.

9.2 USER INSTRUCTION LABEL

The User Instruction label shown below is supplied with each heater. Affix this label adjacent to low level user controls, such as thermostats, time clocks or control panels.

OVERHEAD RADIANT HEATER OPERATING INSTRUCTIONS	
1. TURN ON GAS SUPPLY.	
2. SET TIME SWITCHES OR THERMOSTATS TO DEMAND HEAT.	
3. SWITCH ON ELECTRICITY SUPPLY. RED & AMBER NEON INDICATOR "ON".	
4. BURNER SHOULD IGNITE WITHIN 15 SECONDS, AMBER NEON INDICATOR "ON".	
5. IF IGNITION IS NOT ACHIEVED DURING 12 SECOND IGNITION PERIOD LOCOUT OCCURS. THIS IS INDICATED BY THE AMBER NEON "OFF". INTERRUPT ELECTRICITY SUPPLY TO APPLIANCE FOR 10 SECONDS TO RESET IGNITION CONTROL. IF A FIRST RESET IS NOT SUCCESSFUL, WAIT AT LEAST 15 SECONDS BEFORE REPEATING PROCEDURE. AFTER RESET, AN EXTENDED WAITING TIME WILL OCCUR.	
6. IF FLAME IS LOST DURING NORMAL RUNNING, THE AUTOMATIC IGNITION CONTROL WILL REPEAT START PROCEDURE AS AT 4 ABOVE.	
7. IF THE APPLIANCE FAILS TO IGNITE AFTER SECOND START SEQUENCE, SWITCH OFF ELECTRICITY SUPPLY TO APPLIANCE AND CALL SERVICE ENGINEER.	
8. TO SHUT DOWN APPLIANCE, TURN OFF GAS AND ELECTRICITY SUPPLIES.	
AFFIX THIS LABEL ADJACENT TO LOW LEVEL USER CONTROL.	4260440

Fig. 20

10.0 TYPICAL HEATER ASSEMBLY

! CAUTION	
	<p>CUT HAZARD</p> <p>Sheet metal parts, particularly reflectors and vent have sharp edges. Always use gloves when handling.</p> <p>Failure to do so may result in death, serious injury or property damage.</p>

See heater dimensions and assembly overview (**Sections 7.0 through 8.1**) for each **U-model** and **Linear model** configurations.

During field assembly of the heater body sections, the recommended procedure is as follows:

1. Determine the actual layout of the system first before hanging heater sections. Consideration must also be taken for flue pipe, fresh air ducting, gas piping, clearances to combustibles, etc. before hanging heater.
2. Install the heater suspension using chains or other type methods outlined in Section 9 "**Typical Suspension Methods**". Space these per the assembly overview for each heater.
3. Space two (2) **tube support/hanger brackets** at distances indicated in each assembly overview for the first tube section. **Note:** The distances are measured from center of the slotted holes of each support/hanger bracket.
4. Place **tubes** over these brackets with the welded seam facing down toward the ground. **Failure to assemble the tube with the seam facing down will void the manufacturer's warranty.** Secure the tubes to each support/hanger bracket using U-bolt clamps and 5/16-18 nuts provided.
5. Raise the tube section up to the suspension chain (or other methods), using "S" hooks to attach the tube support brackets. Hang each tube section individually. **DO NOT** assemble all of the heater tube sections together on the ground and attempt to hang the entire system. Provide a slope of 0.25 degree up to the fan on **linear tube heaters**. **Note:** the turbulator is factory installed for linear models 30, 35, 40 and 45 kW, this must be the tube section closest to the exhauster.
6. Continue to pre-assemble and hang each additional section as before. Join each section together using Torctite couplings as described in Section 10.1 "**Tube Coupling Details**".
7. Place **U-bend** (U-model heaters only) as shown in Section 10.2 "**Attaching U-Bend**".
8. Place **main body reflector panels** over each of the tube support/hanger brackets installed above.
9. Attach **burner box** and **fan assembly** as shown in Sections 10.3 and 10.4 respectively.

10. Slide reflector panels and space between burner box and U-bend (U-model heaters only) as indicated on heater dimension drawings. Reflectors must overlap approximately as shown on the dimension drawings.
11. Secure reflectors to tube support/hanger brackets using the screws and clamps (supplied in fastening kits).
Note: Refer to **details A** or **B** of each assembly overview drawing for the required **open** or **closed** positions of the clamps. These positions enable reflectors to slide or remain stationary during operation of heater.
12. Place **end reflector panels** flush to each end of main heater reflector panels and secure by spacing two (2) U-type speed clips (supplied in fastening kits) evenly on edges of each reflector flange.
13. Make all final gas and electric connections as outlined later in the instructions.
14. Affix user instruction label adjacent to controls. See section 9.2.



Failure to assemble the tube with the seam facing down will void the manufacturer's warranty.

10.1 TUBE COUPLING DETAILS

Join the tube sections together and secure with tube couplings as described below. Note: The heater tube section should be provided a slope of 0.25 degree up to the fan.



The following coupling tightening instructions MUST be followed properly to ensure the integrity of the tube connections. Two #10 self-drilling screws MUST be installed at every coupling as shown in the instructions below. Failure to do so may result in serious injury or property damage.

- a. Place the compression coupling over the end of the tube.
- b. Use the small hole at the centerline of the coupling to check that the coupling is inserted correctly.
- c. Partially tighten the bolt nearest the end of the tube (approximately half closed).

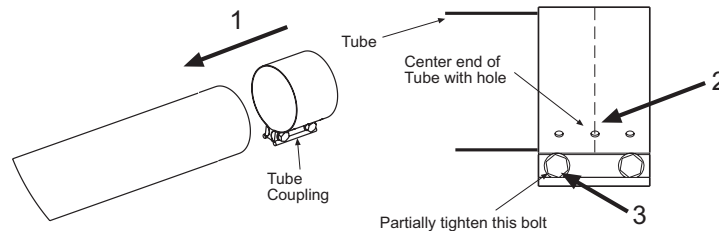

Fig. 21

- d. Slide the next tube into the coupling.
- e. Make sure both tube ends are butted together.
- f. Finish tightening both bolts to 54-80 N-m torque to ensure a complete seal.
- g. Use the two self-drilling screws through the pre-punched holes to secure the tubes in the coupling.

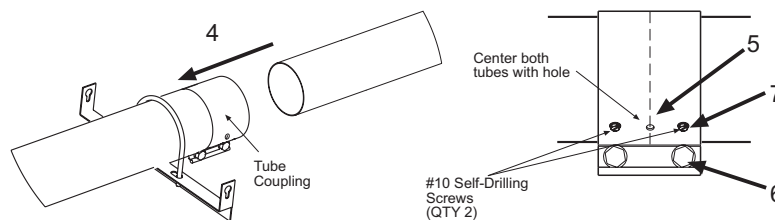
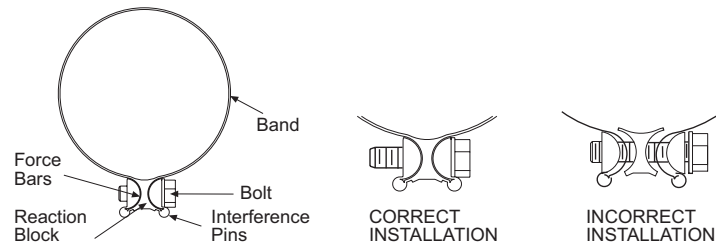

Fig. 22

- h. Check to ensure that the hardware is completely closed and the band is seated on the reaction block and interference pins as illustrated above.

- i. Once all the heater body sections are attached, make sure that the heater system is level. If it is not, slight adjustments can be made using the turnbuckles. (See Section 6.0) **Fig. 23**



Important: NEVER reuse a coupling. Always install a new coupling only and torque as per instructions above and the diagrams above.

10.2) ATTACHING U-BEND

U-Bend (76.2mm Tubes)

1. Assemble the **U-Bend** to the tubes with the two (2) threaded holes facing downwards, ensuring that the tubes engage fully.
2. Using two (2) 5/16" BSW hexagon socket setscrews (from fastening pack) secure the **U-Bend** to the radiant tubes.

IMPORTANT: Failure to assemble the radiant tubes with their welded seam facing away from the reflector will void the manufactures warranty.

U-Bend (101.6mm Tubes)

1. Assemble the **U-Bend** to the tubes, ensuring that the tubes engage fully.
2. Drill one \varnothing 5.5mm hole through the **U-Bend** and radiant tube in the lower surface of each leg at a distance midway along the swaged portion of the **U-Bend**.
3. Rivet the **U-Bend** to the radiant tubes using the two \varnothing 5 x 10 rivets provided (from fastening pack).

IMPORTANT: Failure to assemble the radiant tubes with their welded seam facing away from the reflector will void the manufactures warranty.

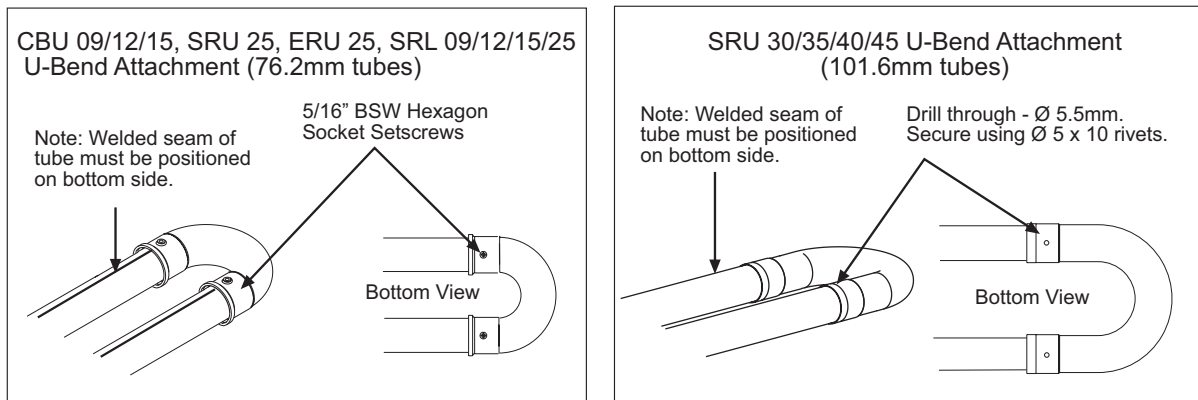

Fig. 25

10.3) ATTACHING BURNER BOX ASSEMBLY

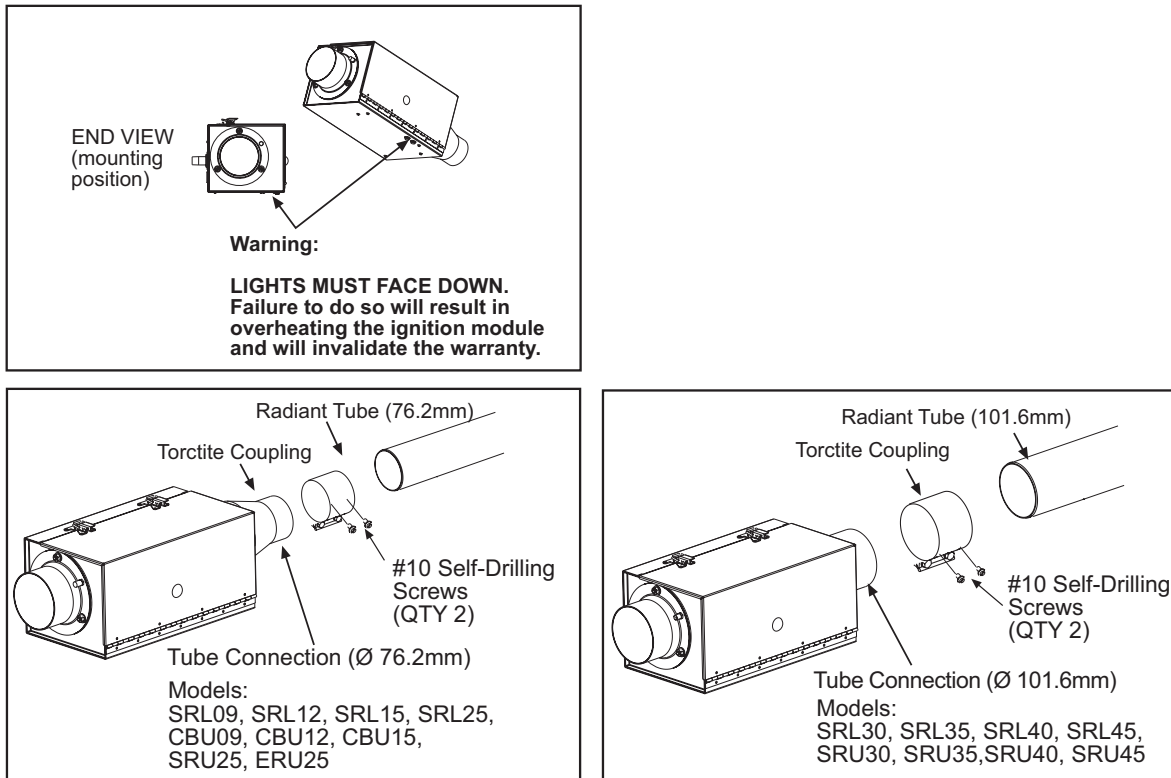

Fig. 26

- a. Place a Torctite Coupling over the end of the Radiant Tube (refer to Section 10.1 "Tube Coupling Details"). Assemble the **Burner Box** to the Radiant Tube ensuring that it engages fully into the Torctite Coupling and is positioned vertically. Tighten the bolts of the Torctite Coupling to secure the **Burner Box** to the Radiant Tube, taking care to support the **Burner Box** in line with the axis of the tube.
NOTE: Tighten the Torctite Coupling bolts alternately while continually checking for slackness of the joint.
- b. Assemble the end reflector flush with the end of the main body reflector. Secure by sliding speed clips (supplied in fastening kit) onto the reflector edges. Evenly space the speed clips on the sides and top of the reflectors to provide a snug fit.

10.4) ATTACHING FAN ASSEMBLY

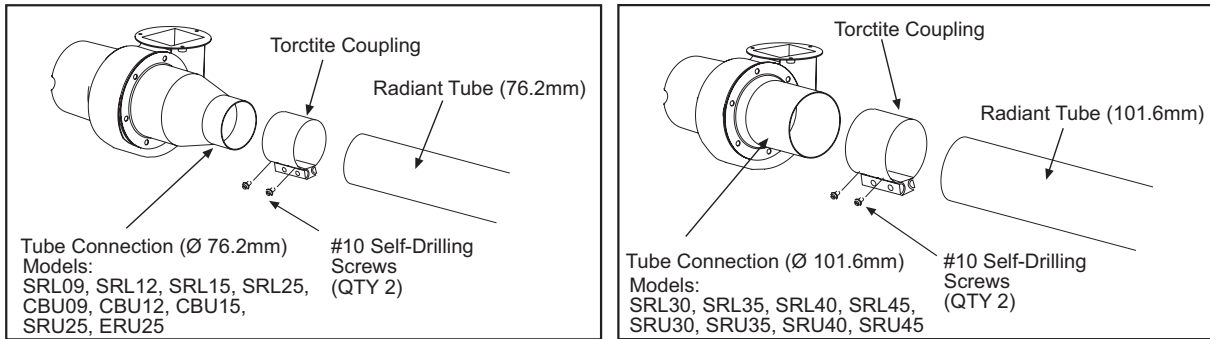
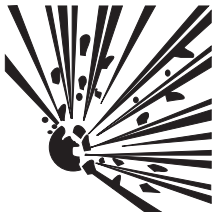



Fig. 27

- Place a Torctite Coupling over the end of the Radiant Tube (refer to Section 10.1 "Tube Coupling Details"). Assemble the **Fan Assembly** to the Radiant Tube and position the fan outlet pointing upwards for flueless applications. Tighten the bolts of the Torctite Coupling to secure the **Fan Assembly** to the Radiant Tube, taking care to support the **Fan Assembly** in line with the axis of the tube.
NOTE: Tighten the Torctite Coupling bolts alternately while continually checking for slackness of the joint.
- Assemble the end reflector flush with the end of the main body reflector. Secure by sliding speed clips (supplied in fastening kit) onto the reflector edges. Evenly space the speed clips on the sides and top of the reflectors to provide a snug fit.

11.0) GAS CONNECTIONS AND REGULATIONS

⚠ WARNING		
		<p>FIRE AND EXPLOSION HAZARD</p> <p>Tighten flexible gas hose and components securely.</p> <p>Flexible metal gas hoses must be installed without any twists or kinks in them. The hose will move during operation of the heater and it can crack if it is twisted.</p> <p>Failure to do so may result in death, serious injury or property damage.</p>

IMPORTANT BEFORE CONNECTING THE GAS TO THE HEATER

- Connect to the supply tank or manifold in accordance with state or local building codes. Authorities having jurisdiction should be consulted before the installation is made.
- Check that the gas fuel on the burner rating plate matches the fuel for the application.
- Check that the gas supply piping has the capacity for the total gas consumption of the heaters and any other equipment connected to the line.
- Check that the calculated supply pressure with all gas appliances and heaters operating will not drop below the minimum supply pressure required for these heaters. See Table 15 Below.

Table 15

Gas type	Appliance Category	Nominal Supply Pressure	Maximum Supply Pressure	Minimum Supply Pressure	Setting Pressure
Natural Gas (G20)	2 _H	20 mbar	25 mbar	17 mbar	12.5 mbar
LPG (G31)	3 _P	37 mbar	45 mbar	30 mbar	25 mbar

- All gas supply lines must be located in accordance with the required clearances to combustibles from the heater as listed on the clearances label of the heater and (Section 4.0) of this manual.
- Pipe joint compounds must be resistant to the action of liquefied petroleum gases.
- Tube heaters will expand/contract during operation. Use an approved flexible connector for connections between the rigid piping and the heater. A union should be installed before the control box inlet. An approved shut off valve should be installed within 1.8m of the union.

- h. The gas pipe, flexible hose and connections must be self supporting. The gas pipe work must not bear any of the weight of the heater or any other suspended assembly.
- i. This appliance is equipped with a step-opening, combination gas valve. **The maximum supply pressure to the appliance is 60 mbar.** If the line pressure is more than the maximum supply pressure, then a second stage regulator which corresponds to the supply pressure must be used.
- j. After all gas connections have been made, make sure the heater and all gas outlets are turned off before the main gas supply is turned on slowly. Turn the gas supply pressure on and check for leaks.
- k. If a 2nd stage regulator is used, the ball valve down stream in the supply line must be closed when purging the gas lines to prevent gas seeping through it. If initial gas pressure is higher than 60 mbar the redundant combination gas valve is designed to lock out. Pressure build-up in the supply lines prior to the heater must be released before proper heater operation.

⚠ WARNING

Do not use an open flame of any kind to test for leaks.

KEY DIMENSIONS AND COMPONENTS OF THE GAS CONNECTIONS

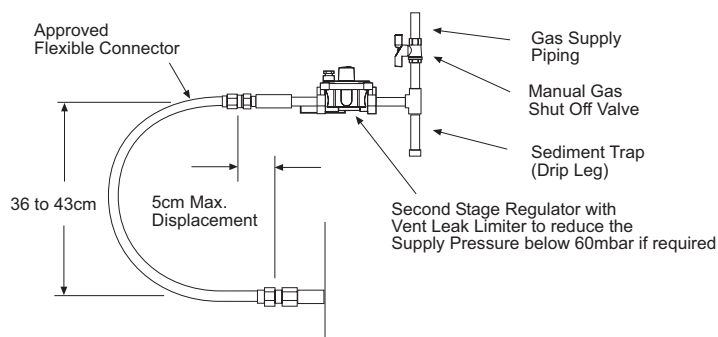

Fig. 28

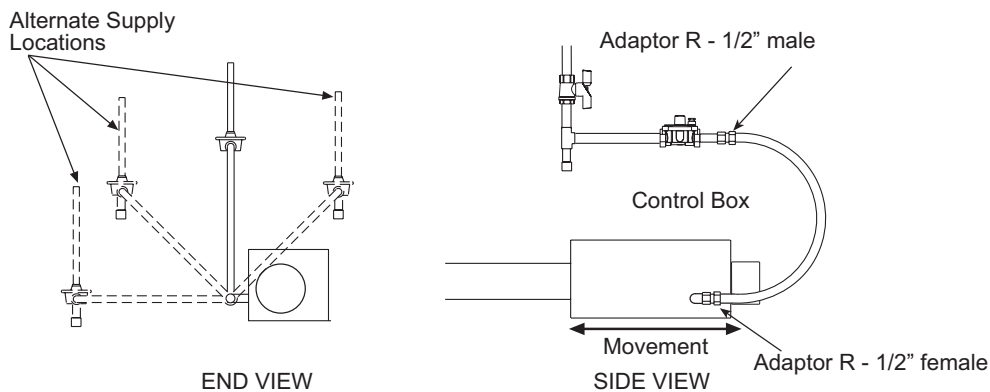

Fig. 29

INCORRECT POSITIONS

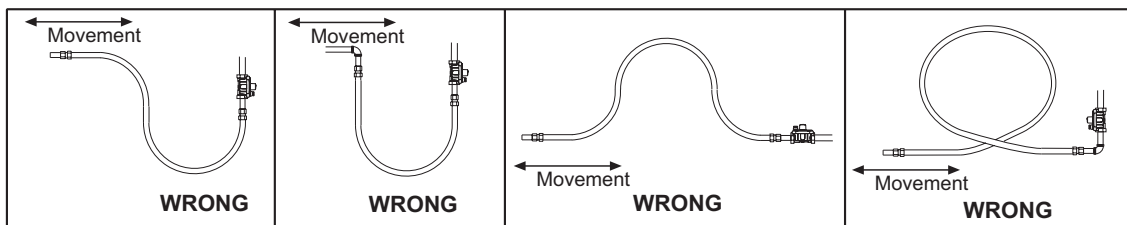

Fig. 30

Radiant tube heaters will expand and contract during operation. Therefore it is essential to provide a flexible metallic hose, which must conform, to national or Local Regulations, to connect the appliance to the gas supply. Minimum size to be 1/2" (12.7mm) bore.

The gas pipe, flexible hose and connections must be self supporting. The gas pipe work must not bear any of the weight of the heater or any other suspended assembly.

! WARNING

Do not use an open flame of any kind to test for leaks.

12.0) INSTRUCTIONS FOR PRESSURE TEST GAUGE CONNECTION

CHECKING GAS PRESSURES

- Switch off the electricity supply to the appliance.
- Connect a manometer to the test nipple protruding from the rear panel of the Control Box (adjacent to the Air Inlet Adaptor). See Fig. 31. Open the Control Box door after releasing the two toggle latches.

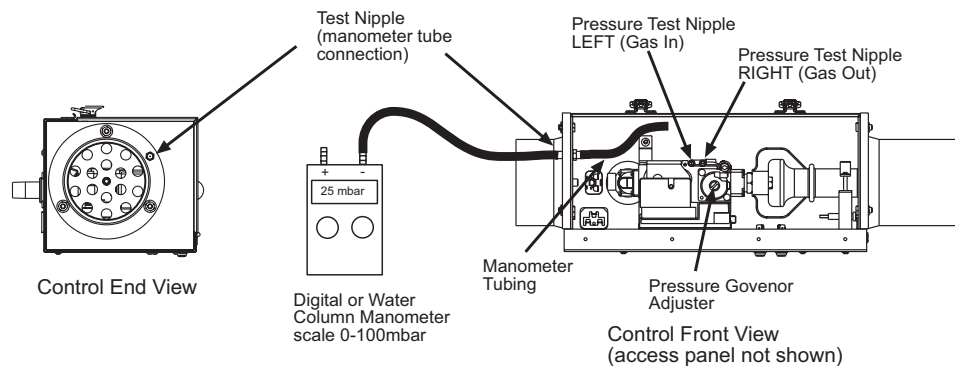

Fig. 31

TO CHECK THE GAS SUPPLY PRESSURE

- Unscrew the sealing screw (two turns) of the LEFT (Gas IN) Control Valve test nipple and connect the free end of the manometer tube (permanently connected to the manometer test nipple inside the side panel of the control box) to this test nipple (See Fig. 31). Close the control box door and secure with the two toggle latches.
- Ignite the appliance burner by switching on the electricity supply to the appliance and check that the manometer reading is as stated below for the gas type the appliance is "adjusted for" (see the Data Label affixed to the Control Box door). See table 15 for gas supply.
- Switch off the electricity supply to the appliance open the control box door and remove the manometer tube from the LEFT (Gas IN) control valve test nipple. Screw in the test nipple sealing screw.

TO CHECK THE BURNER SETTING PRESSURE

- Unscrew the sealing screw (two turns) of the RIGHT (Gas OUT) Control Valve test nipple and connect the free end of the manometer tube (permanently connected to the manometer test nipple inside the side panel of the control box) to this test nipple (See Fig. 31). Close the control box door and secure with the two toggle latches.
- Ignite the appliance burner by switching on the electricity supply to the appliance and check that the manometer reading is as stated below for the gas type the appliance is adjusted for (see the Data Label affixed to the control box door).

Category 2H: gas type G20 (natural): setting pressure 12.5mbar

Category 3+: gas type G31 (propane): setting pressure 25mbar

- In the event that the burner setting pressure is incorrect, switch off the electricity supply to the appliance and remove the cap from the integral pressure governor for the Control Valve (see Fig.). Close the control box door and switch on the electricity supply to the appliance to ignite the burner. Remove the plug from the control box door and insert a suitable screwdriver through the exposed hole in the box to locate the governor adjusting screw. Adjust the pressure by turning the pressure governor adjusting screw clockwise to increase or anti-clockwise to decrease the burner setting pressure. See Fig. 32.

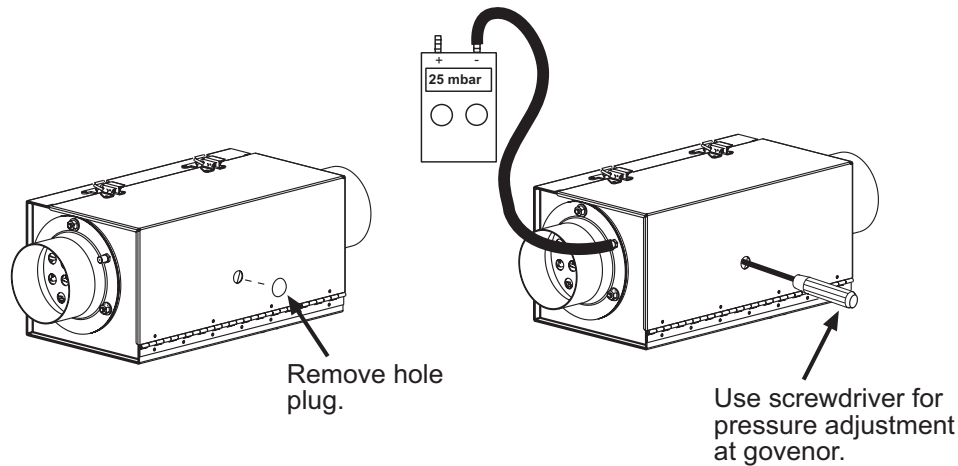

Fig. 32

- d. Upon obtaining the correct burner setting pressure switch off the electricity supply to the appliance, remove the screwdriver, replace the plug into the upper surface of the control box door and open the door. Remove the manometer tube from the RIGHT (Gas OUT) Control Valve test nipple and screw in the test nipple sealing screw. Close the control box door and secure with the two toggle latches.

FLAME SUPERVISION

- a. To check the operation of the flame supervision equipment, run the appliance normally, turn off the gas supply at the gas isolation valve and observe that the amber neon indicator remains illuminated.
- b. After a purge period of 10 seconds (minimum) the solenoid valves and the ignition spark electrode will be re-energized and with the gas still turned off, the ignition control will go to "lockout" condition after a further 12 seconds (maximum). Amber neon indicator extinguished.
- c. Switch off the electricity supply to the appliance for a period of 10 seconds before attempting to re-ignite the burner. (see Section 15).

13.0) ELECTRICAL CONNECTIONS

⚠ WARNING	
	ELECTRIC SHOCK HAZARD
	Disconnect electrical power and gas supply before servicing.
	This appliance must be connected to earth. Failure to do so may result in death or serious injury.

- a. The electrical wiring to this heater must be installed in accordance with the latest or current National Regulations and any Local Regulations, which apply.

Electrical supply	230V~50Hz 125W
Current rating	0.55
Fuse externally	3A
- b. Twin core and earth PVC covered flexible supply cable (0.5mm²-to National or Local standard specification) must be used, with connection made as follows:

Single Heaters per Thermostat connection diagram

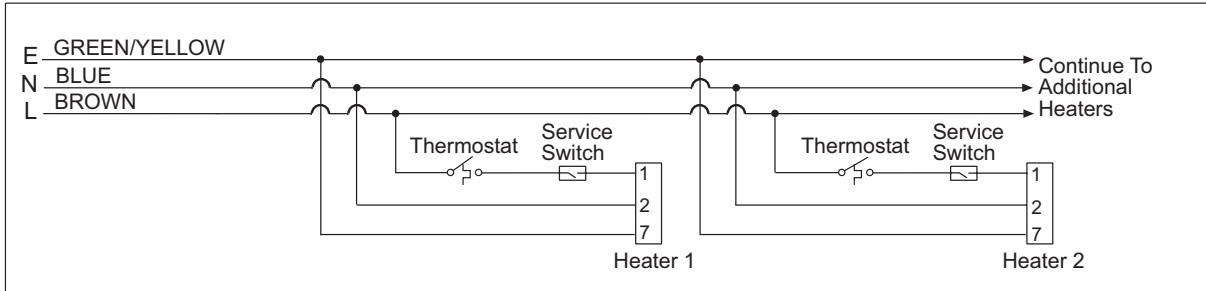

Fig. 33

Multiple Heaters per Thermostat connection diagram

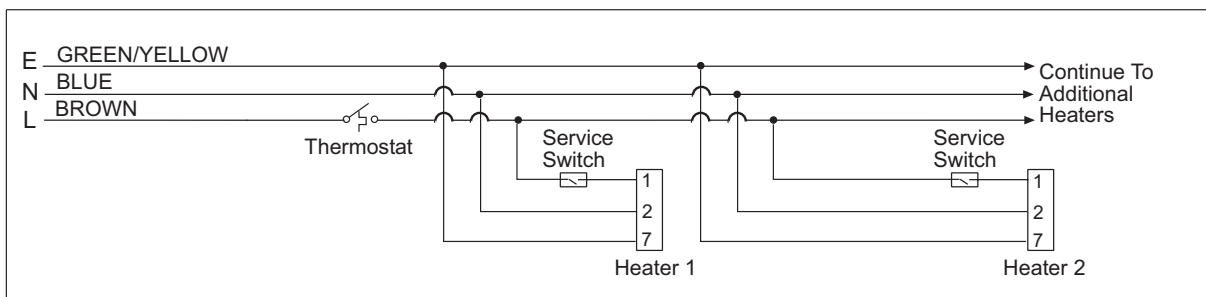

Fig. 34

Notes: The method of connection to the electrical supply must facilitate complete isolation and should preferably be via a fused double pole isolator having a constant separation of at least 3mm in all poles and supplying the appliance ONLY.

Alternatively, connection may be made via a fused 3 pin plug and un-switched, shuttered socket, both complying with the requirements of National or Local Regulations. Neither thermostat nor switch are supplied as standard equipment. NOTE: In the event of an electrical fault after installation of the appliance, preliminary system checks are required to be carried out i.e. earth continuity, polarity and resistance to earth.

c. Internal Wiring Diagram

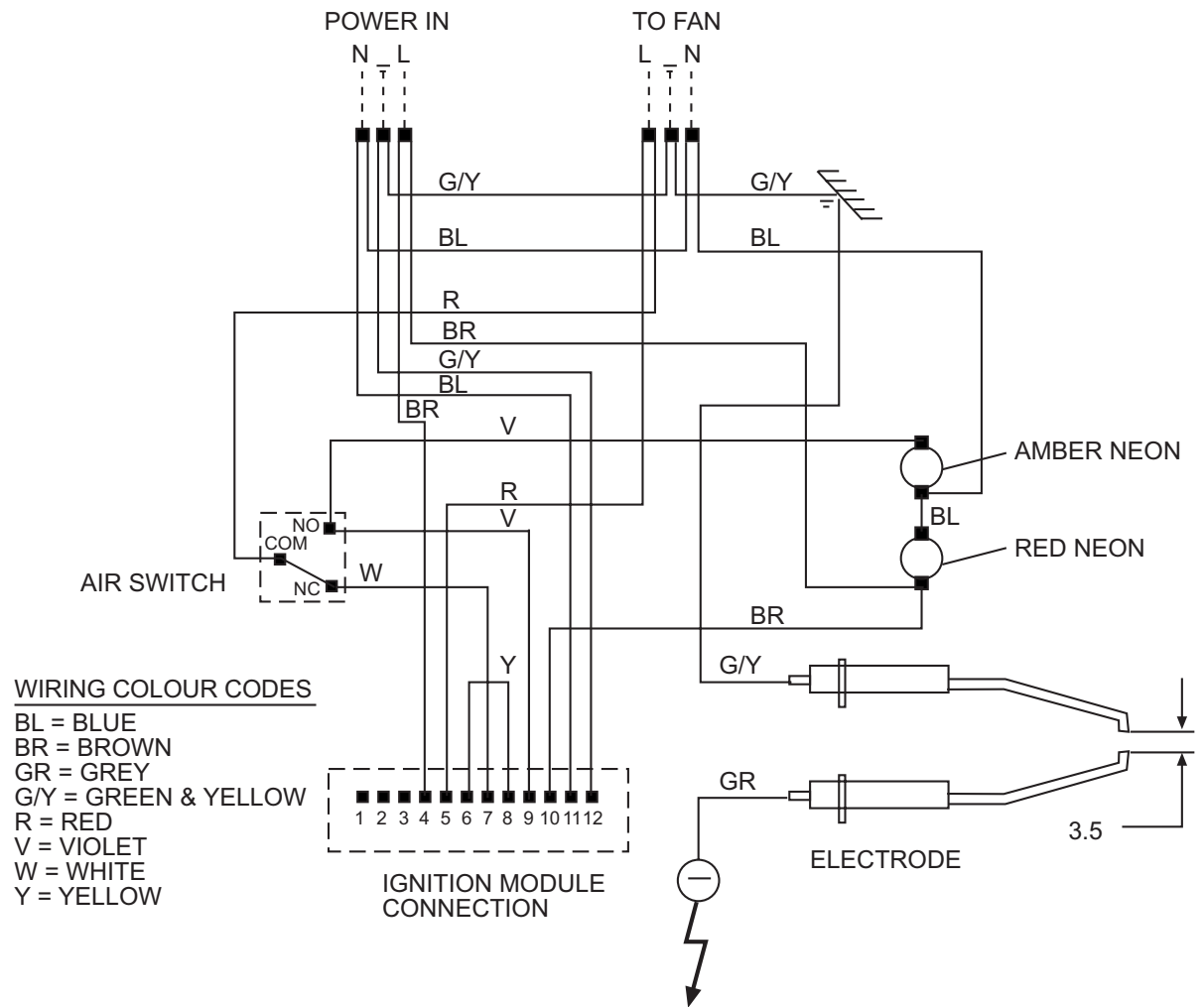
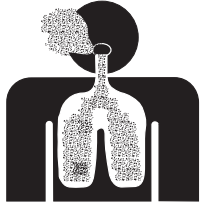

Fig. 35

14.0) VENTING AND FRESH AIR FOR COMBUSTION

⚠ WARNING	
	<p style="text-align: center;">POISONOUS GAS AND SOOT HAZARD</p> <p>Heaters installed unvented must be installed in an area with at least 10m³ / hr per kW heat input of outside air ventilation.</p> <p>In buildings with airborne contamination such as poultry houses the heater must be installed with fresh air for combustion.</p> <p>Failure to do so may result in death, serious injury, property damage or illness from Carbon Monoxide poisoning.</p>

These appliances may be installed with an exhaust flue fitted **or** without an exhaust flue fitted.

A. FLUELESS (UNFLUED)

The installation room should have a volume of at least 10m³/kw of installed nominal heat input of the radiant heater.

The ventilation requirements and calculation methods for unflued appliances are set out in the European Standards **EN 13410:2001** and must be applied. The following is guidance to the standard:

Ventilation may be achieved by any of the three following different means:

- a) Thermal evacuation of the products of combustion/air mixture
- b) Mechanical evacuation of the products of combustion/air mixture
- c) Natural air change

VENTILATION BY THERMAL EVACUATION

- a. Ventilation by thermal evacuation is sufficient if 10m³/h of exhaust air per kW of operating heat input are ventilated out of the installation room.
- b. The air/products of combustion mixture must be evacuated above the radiant heaters, if possible near the ridge, by means of exhaust mixture opening(s), (vents).
- c. Where the exhaust mixture opening(s) can be closed, it shall only possible to operate the radiant heaters when they are open.
- d. The maximum horizontal distance between a radiant heater and a vent opening shall be:
6 (six) times the vent height in the case of wall openings
3 (three) times the vent height in the case of roof openings

VENTILATION BY MECHANICAL EVACUATION

- a. Ventilation by mechanical evacuation is sufficient if 10m³/h of exhaust air per kW of operating heat input are ventilated out of the installation room.
- b. The air/products of combustion mixture must be evacuated above the radiant heaters using fan(s).
- c. It shall only be possible to operate the radiant heaters whilst the exhaust airflow is proven.
- d. The maximum horizontal distance between a radiant heater and a fan shall be:
6 (six) times the fan mounting height in the case of wall openings
3 (three) times the fan mounting height in the case of roof openings
- e. Total minimum proven ventilation airflow in m³/h will be:
Total installed kW input X 10

Note: Mechanical exhaust air openings must be positioned such that the burner stability of the nearest appliance is unaffected.

VENTILATION BY NATURAL AIR CHANGE

Gas-fired radiant heaters may be operated without any special exhaust system if the exhaust gases are discharged to the outside atmosphere by a sufficient natural air change in the installation room.

Furthermore, no provision for thermal or mechanical ventilation is required in the following particular cases:

Buildings with natural air change greater than 1.5 volumes per hour

Buildings with a density of operating heat input not greater than 5W/m³

AIR SUPPLY

Air supply openings are required to admit air and shall be located below the radiant heaters.

The total area of the unobstructed cross-sections of all the air supply openings shall not be smaller than the total area of the unobstructed cross-sections of all the exhaust openings.

Slits and gaps of fixed cross-section can also be used as air supply openings.

Where the air supply openings can be closed, it shall only be possible to operate the radiant heaters when they are open.

B. FLUED

If the appliance is to be flued externally, then flue pipe of diameter stated in Table 12, and complying with National and Local Regulations should be used.

IMPORTANT: When flued horizontally, the flue pipe must be arranged to provide a continuous rise from the appliance of 25mm per 1m length.

The ventilation requirements for flued appliances are set out in **BS 6896:1991** and must be applied. The following is guidance to the standard:

NATURAL VENTILATION

Low level ventilation shall be provided in all cases below the level of the heater(s).

Up to and including 60kW: 4.5cm²/kW

Over 60kW: 270cm² + 2.25cm² /kW in excess of 60kW total rated heat input.

Where the air supply openings can be closed, it shall only be possible to operate the radiant heaters when they are open.

MECHANICAL VENTILATION

Ventilation shall be provided in all cases at or below the level of the heaters.

Minimum proven air flow: 2.35m³/h/kW of total rated heat input.

It shall only be possible to operate the radiant heaters whilst the ventilation airflow is proven.

C. FLUE AND COMBUSTION AIR CONFIGURATIONS

The heaters can be installed with different flue and combustion air configurations please review the diagrams on the following page for the overview of the permitted installations. The permissible maximum lengths associated with these options are listed in the table below.

Table 16

Flue Type	Max Combustion Air 100mm Ø	Max Flue Length 100mm Ø	Max flue length Concentric 150/100mm Ø	Max length combined combustion air and flue	Reduce length for 90° bends 100mm Ø	Reduce length for 90° bends concentric
A ₂	15m	N/A	N/A	15m	-1.7m	N/A
B ₂₂	13m	15m	N/A	28m	-1.7m	N/A
C ₁₂ ¹	8m + 1m	8m + 1m	1m + 8m + terminal	9m	-1.7m	-2.5m
C ₃₂ ¹	8m + 1m	8m + 1m	1m + 8m + terminal	9m	-1.7m	-2.5m
C ₅₂	13m	15m	N/A	28m	-1.7m	N/A

Note¹: first length is parallel section second length is concentric section.

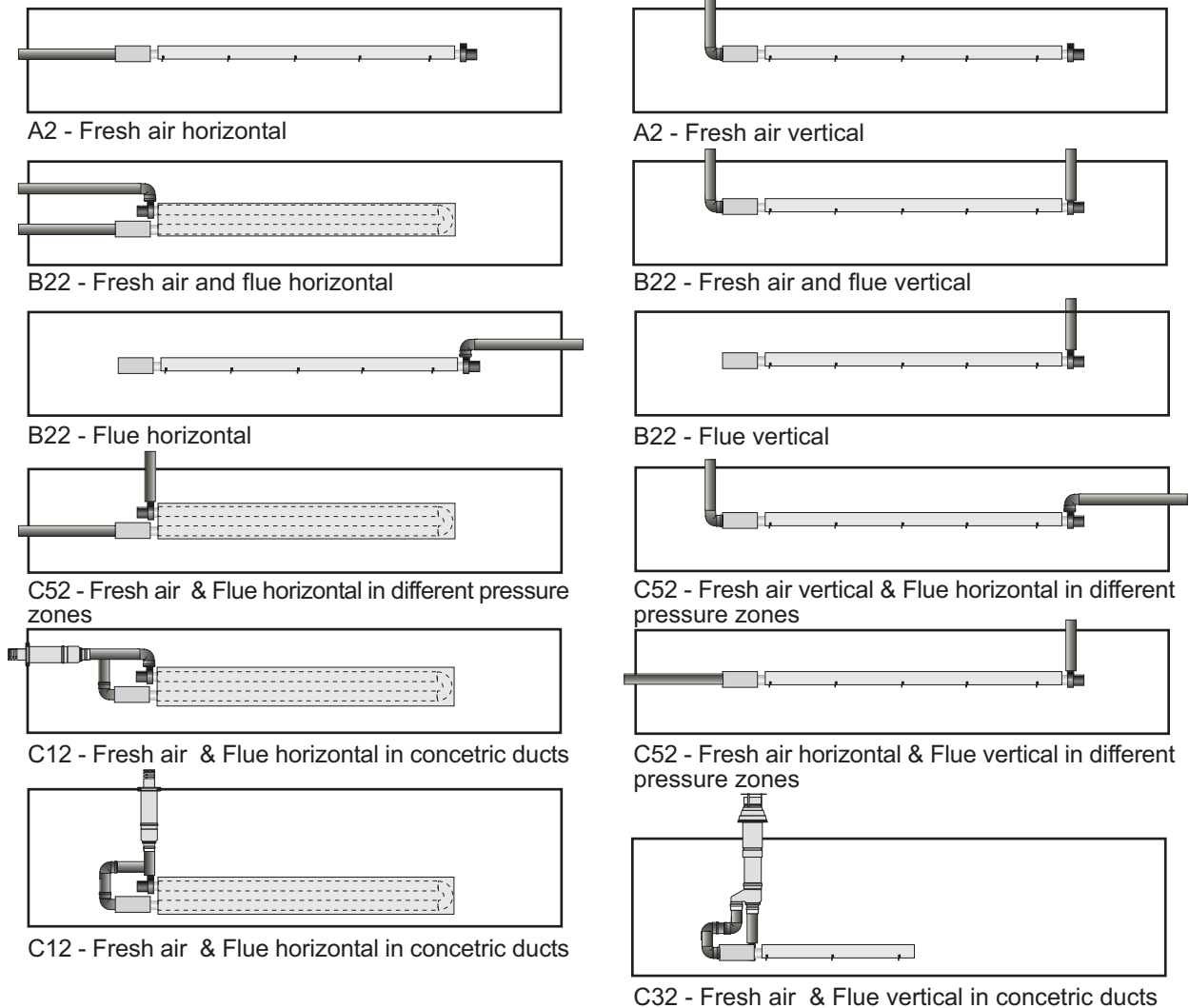

Fig. 36

16.1 Type A₂:

Outside (ducted) combustion air supply. When installed in a dusty or polluted atmosphere, the heater should be fitted with a ducted supply of clean fresh air. A length of 100mm flexible ducting should be installed between the Control Box Air Inlet and any rigid ducting and be secured to the Air Inlet with hose clips.

Where outside combustion air is ducted directly to the burner(s) the low level **natural** ventilation openings shall be not less than 50% of the areas given in 6.4.2.1 above.

16.2 Type B₂₂:

When installing external flue single duct systems with ducted combustion air supply the distance between the flue terminal and fresh air intake shall be no less than 1 m for both vertical and horizontal systems

16.3 Type C₁₂:

The following figure shows the typical arrangements for concentric sidewall flues, see table 16 for 90° bend equivalent lengths. The bends shown in the illustrations connecting the combustion air intake to the concentric ducts is calculated into the overall length. For example a system with one additional 150/100mm Ø concentric 90° bend can be installed with 1m 100mm flue single pipe and the combustion air single pipe as shown with 5.5m of 150/100mm Ø straight concentric flue. (8m - 2.5m from table 16)

Components		
Nr	Supplier	Description
1.	M & G	Wall Terminal 150/100mm
2.	M & G	Concentric vent 150/100mm
3.	M & G	Flue Single pipe 100mm (Max 8m)
4.	M & G	Combustion Air single pipe 100mm.
5.	M & G	Elbow single pipe 100mm (3 shown)
6.	Space-Ray	Fresh air connector
7.	Space-Ray	Flue connector

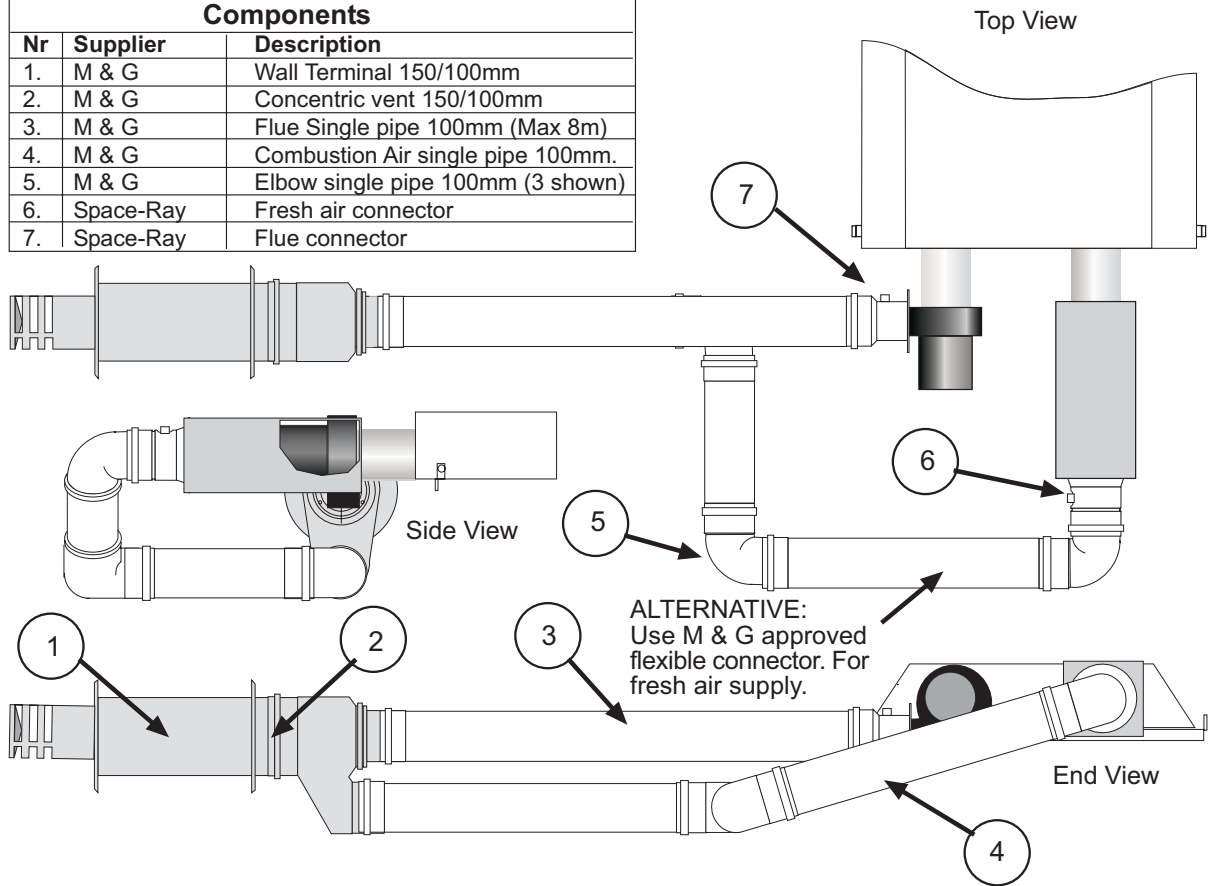

Above shows typical arrangement for flue to the side of the heater

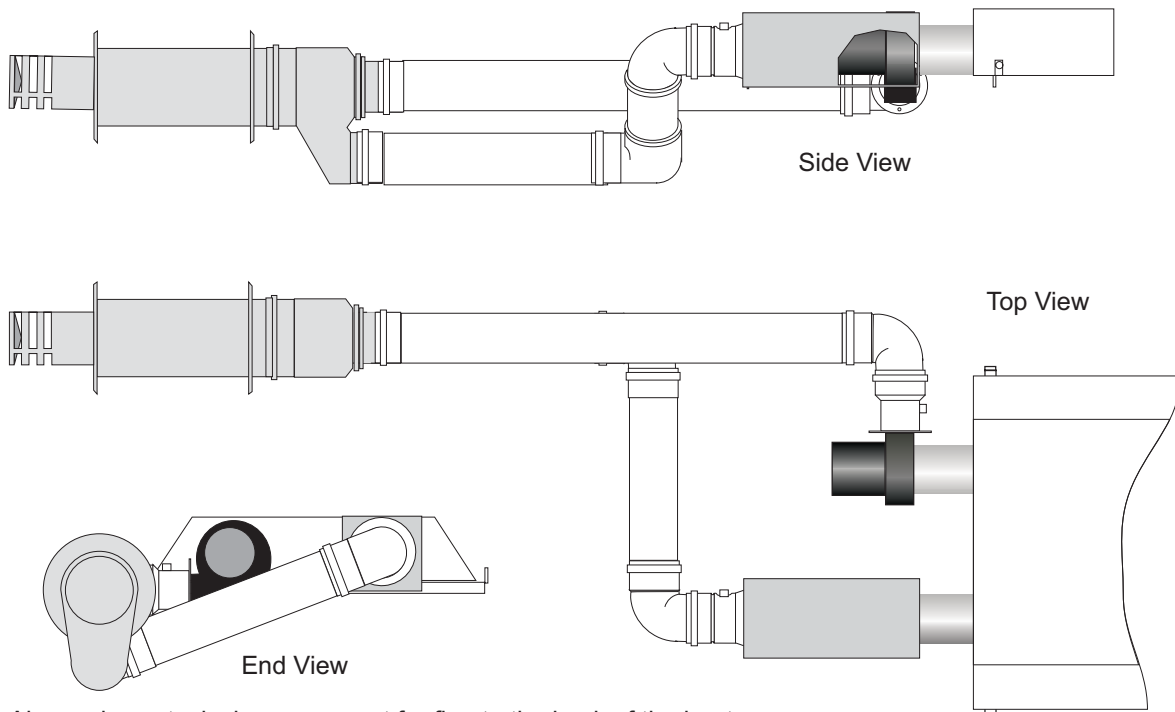

Above shows typical arrangement for flue to the back of the heater

Fig. 37

16.4 TypeC₃₂:

The following figure shows the typical arrangements for concentric vertical flues, see table 16 for 90° bend equivalent lengths. The bends shown in the illustrations connecting the combustion air intake to the concentric ducts is calculated into the overall length. For example a system with one additional 150/100mm Ø concentric 90° bend can be installed with 1m 100mm flue single pipe and the combustion air single pipe as shown with 5.5m of 150/100mm Ø straight concentric flue. (8m – 2.5m from table 16)

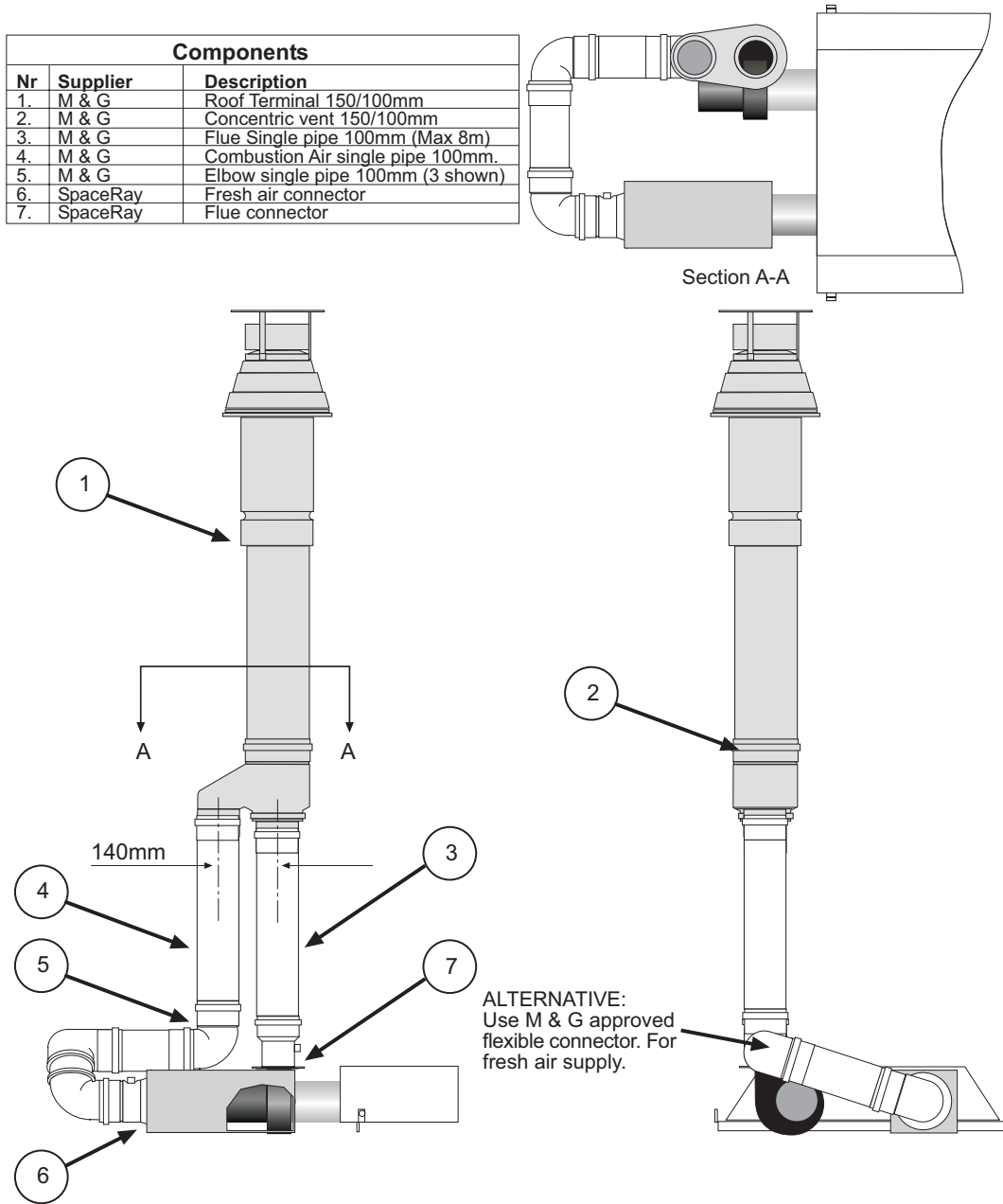

Fig. 38

16.5 TypeC₅₂:

When fresh air for combustion and the flue outlet are from different pressures zones as shown in figure 36, the flue outlet and the fresh air intake must not be on surfaces that are 180 degrees apart. The acceptable configurations are those shown in figure 38 in combination with the maximum lengths listed on table 16.

16.6 Type C fresh air connector:

The connectors for the Type C fresh air are supplied as an accessory. The installation steps for the Type C connector are shown in figure 38a below.

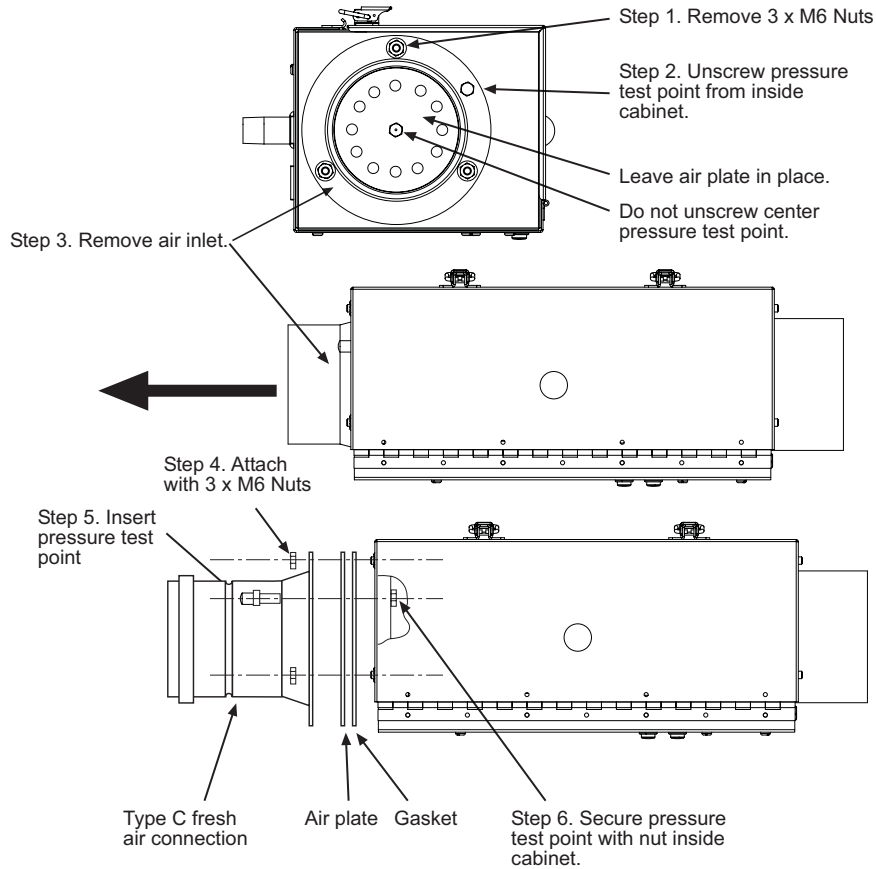

Fig. 38a

15.0) LIGHTING AND SHUTDOWN INSTRUCTIONS

- Ensure that the Control Box lid is closed and secured with the two toggle latches. The heater will not operate with the door open.
- Turn on the gas supply to the appliance.
- Set any time switches or thermostats to demand heat.
- Switch on the electricity supply to the appliance. The red neon indicator and amber neon indicator will be illuminated.
- The burner should ignite within 20 seconds. Both red and amber neon indicators will remain illuminated.
- Failure to ignite will result in the ignition controller going to "lockout" condition. The red neon indicator will remain illuminated. The amber neon indicator will be extinguished.
- If lockout occurs, switch off the electricity supply to the appliance; wait for 10 seconds before switching on the electricity supply to the appliance to repeat the ignition sequence.
- If the appliance fails to ignite after a second sequence switch off the electrical supply to the appliance and call the service engineer.
- If gas failure occurs after successful ignition the appliance will attempt one re-ignition before going to lockout condition.
- To shut down the appliance for short periods of time, switch off the electricity supply to the appliance.
- To shut down the appliance for longer periods of time, switch off the electricity supply to the appliance and turn off the gas supply at the gas isolation valve.

NOTE: The lighting and shutdown instructions are also shown on a permanent label attached adjacent to the controls for the heater (see section 9.2).

16.0) COMMISSIONING

The chart below shows the sequence of operation for the normal operating cycle.

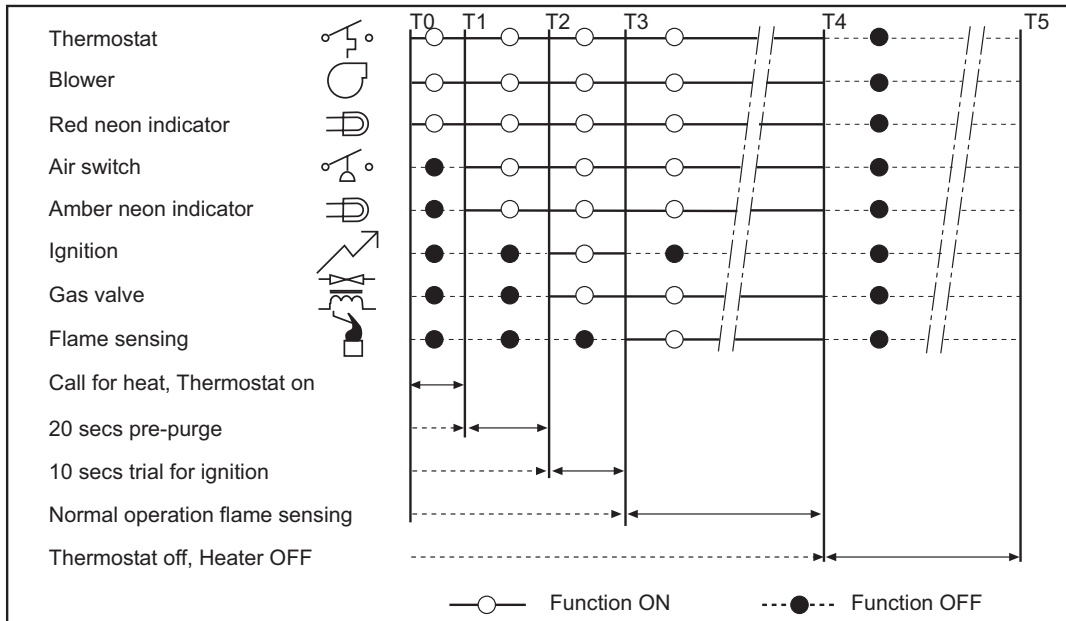

Fig. 39

If the flame is not sensed during sequence T3 then the heater will go to lockout.

It is essential that all new pipework installations are purged and tested for soundness with a suitable leak detection fluid prior to attempting to ignite any appliance. This work should be carried out in accordance with National or Local regulations.

NOTE: DO NOT TEST FOR SOUNDNESS BY USE OF NAKED FLAMES.

17.0) CLEANING AND ANNUAL MAINTENANCE

⚠ WARNING

ELECTRIC SHOCK & EXPLOSION HAZARD

Disconnect electrical power and gas supply before servicing.

Failure to do so may result in death or serious injury.

This heater must be cleaned and serviced annually by a qualified contractor before the start of each heating season and at any time excessive accumulation of dust and dirt is observed. Maximum heating efficiency and clean combustion will be maintained by keeping the heater clean.

It is essential that at least once a year, preferably before the heating season, a qualified person service the appliance. In exceptionally dirty conditions, more frequent servicing may be desirable.

IMPORTANT:

- a. Do not rest anything, especially ladders, against the appliance.
- b. Gas and Electricity supplies must be isolated before commencing servicing work or replacement of components.

- c. On completion of a service/fault finding task which has required the breaking and remaking of electrical corrections, the following checks, using a multi-meter must be made.
1. Earth continuity check
 2. Polarity check
 3. Resistance to earth check

The contractor shall check the following during periodic maintenance.

- **Clearances to combustibles:** Check that clearances are being maintained. Make sure there are no flammable objects, liquids or vapors near the heater. See also Section 4.0).
- **Reflectors:** Reflectors should be kept clean, at a minimum blow off the reflectors. (Dirty reflectors will reduce heat output).
- **Heat exchanger tubes:** Inspect the heat exchanger tubes to make sure they are not cracked, sagging or showing signs of fatigue.
- **Combustion air intake:** Disconnect combustion air intake from the control box and inspect internally using a flashlight to make sure no foreign material has collected in the tubes and that there is no obstruction around the air intake openings. Clean any foreign materials. Inspect any joints to make sure they are completely sealed. See also Section 14.
- **Venting System:** Disconnect vent pipe and inspect internally using a flashlight to make sure no foreign material has collected in the pipes. Check the external vent cap and make sure that there is no obstruction around the exhaust openings. Clean any foreign materials. Inspect any joints to make sure they are completely sealed. See also Section 14.
- **Gas lines:** Make sure that the gas lines are not leaking. Check the gas connection to the heater for any signs of damage, fatigue or corrosion. If there are any signs of damage to the gas connection or leaks found in the gas piping, immediately stop using the heater until the gas pipe and connections have been repaired or replaced. Check that the gas lines are not bearing the weight of the heater. See also Section 11.
- **Burner Box:** In order to extend the longevity of the heater, the heat exchanger tube and the burner must be level. Check that the burner box is level; use the turnbuckle on the burner suspension eyebolt to adjust the level of the burner. See also Section 9.1.
- **Blower wheel and housing:** Check that the blower wheel spins freely, blow out any dust or dirt with compressed air.
- **Electrode condition:** Visually check that the electrode gap is maintained at 3.5mm and that the tips of the flame sensor and spark electrode are free from deposits. Clean off any deposits. Check that the electrode ceramic is free from cracks. See Section 19.1.
- **Suspension system:** Check that the suspension system is holding the heater level. Make sure that the heater is hanging securely, look for any evidence where the heater may have been hit accidentally and tighten any loose hanging points. Check that S hooks are closed. Check that there is no evidence of wear on the chain at the connection to the heater and at the ceiling.
- **Main Burner and Orifice:** Check the Main burner and orifice; remove any dirt or debris including spider webs. See Sections 19.2 and 19.3 .
- **Electrical Wiring:** Check that all the electrical connections are sound and that the wiring is undamaged. Replace damaged wires as necessary.
- **Air Inlet / Baffle Plate:** Check that the air inlet holes in the Baffle Plate, which is clamped between the Control Box side panel and the Air Inlet flange, are clear from obstructions. Check also, that the wire mesh panel of the Air Inlet is clean. Clean as necessary using a soft brush. In the case of an appliance having a ducted air supply, it will be necessary to disconnect the flexible ducting from the Air Inlet by first releasing the hose clip. If it is necessary to remove the Air Inlet to adequately clean the Baffle Plate it will be necessary to replace the gasket seal (see Section 19.8).
- **Door Seal:** Check the condition of the seal around the Control Box door and replace as necessary.
IMPORTANT: The appliance will not function unless the seal around the control box door is sound and the door secured with the two toggle latches.
- **Flue Pipes:** For flued appliances it is important that periodic sweeping of the flue is carried out according to the National or Local regulations in force.
- **Auxiliary Controls:** Room thermostats, time switches, frost thermostats etc should be checked to ensure correct functioning, and are set to the user requirements.
- **Re-assemble and Commission:** Re-assemble the appliance in reverse order and commission in accordance with the instructions contained in Section 16.0.

Troubleshooting continued from the previous page.

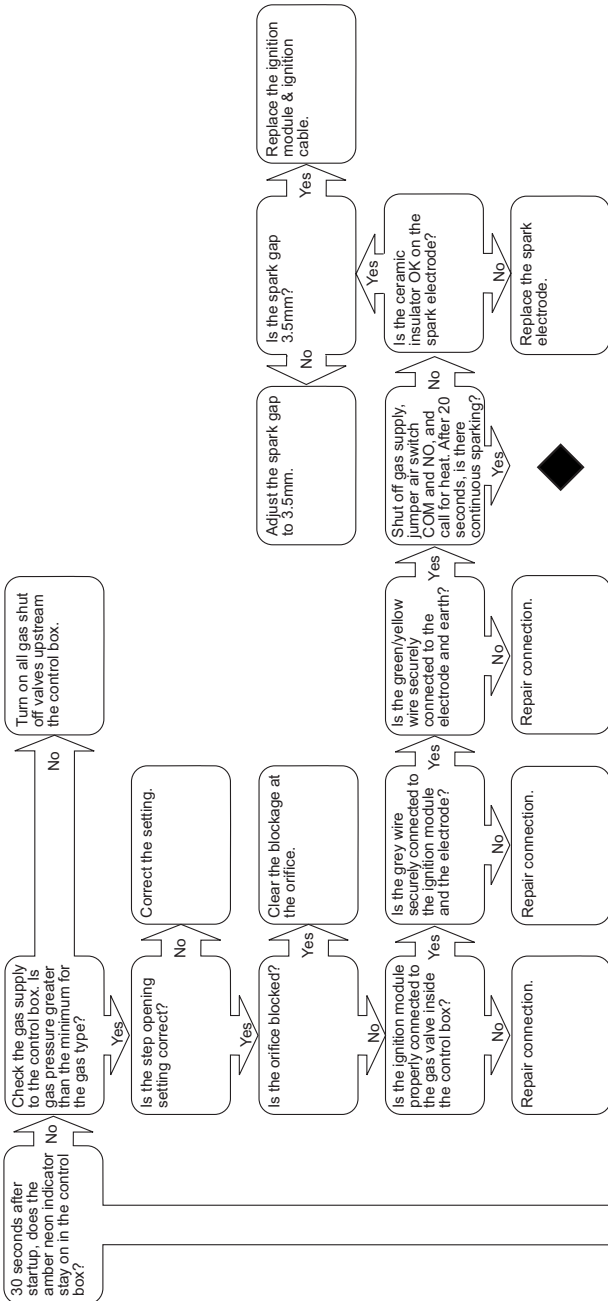

Troubleshooting ends.

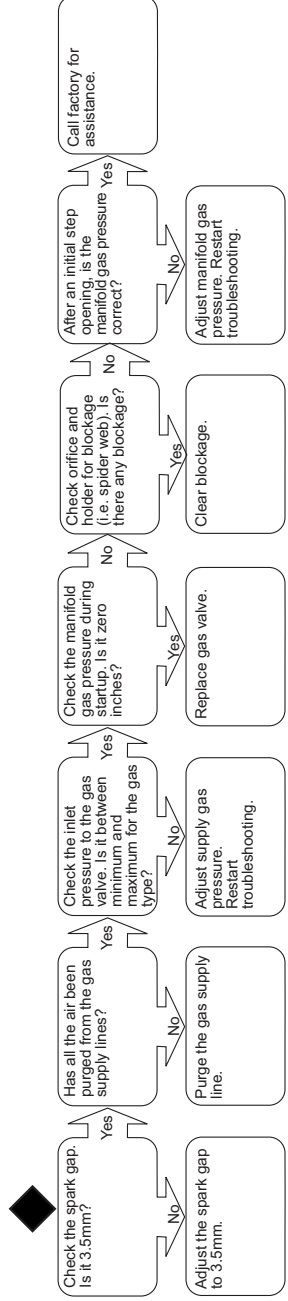

19.0) REPLACING PARTS

⚠ WARNING

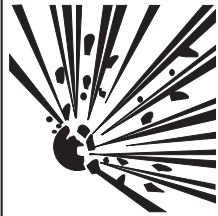
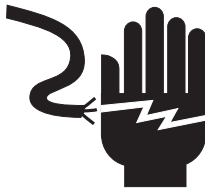

ELECTRIC SHOCK & EXPLOSION HAZARD

Disconnect electrical power and gas supply before servicing.

Failure to do so may result in death or serious injury.

Only use genuine Space-Ray replacement parts. Parts are available from the factory for replacement by a licensed person. Refer to the Replacement Parts Guide in Section 0 for all replacement parts.

IMPORTANT: Disconnect gas and electricity supplies to the appliance before carrying out any repair work. This work can be carried out at high level using a purposes designed access tower, but it is preferable that this work should be carried out at ground level.

19.1) REMOVAL OF ELECTRODES

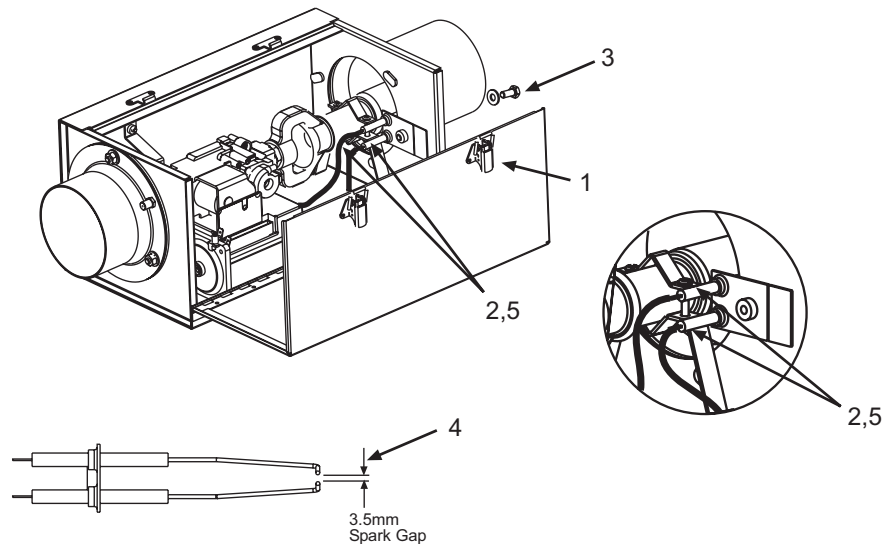

Fig. 40

This range of radiant tube heaters employs a single probe electrode system whereby both the spark generation and flame supervision operations are carried out via a common electrode. The second electrode provides the earth path for the ignition spark. The two electrodes are identical, therefore either lead (grey HT or green/yellow - earth) may be connected to either electrode.

1. Open the Control Box door after releasing the two toggle latches.
2. Disconnect the grey HT ignition/flame sensor lead and the green/yellow earth lead from the electrodes by gently pulling the connectors, using pliers.
3. Unscrew the M6 x 16 set-screw securing the electrode carrier to the Control Box and remove the Electrode Assembly.
4. Remove any foreign matter from the Electrode tips and check that the spark gap is 3.5mm. If the Electrode rods are badly oxidized, replace the electrodes.
5. Upon re-assembly, ensure that the HT lead and earth lead connectors are securely attached to the Electrodes.

19.2) REMOVING MAIN BURNER

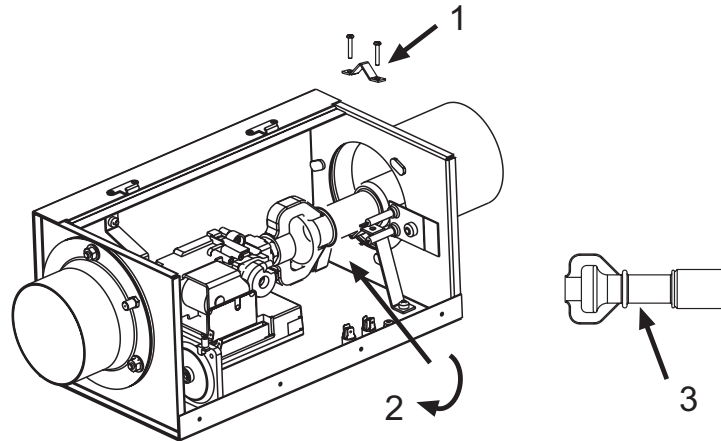

Fig. 41

1. Open the control box door; unscrew the two M4 x 25 setscrews from the Burner Bracket and remove the Burner Clamp.
2. Unscrew the Burner from the Injector Fitting
3. Lift the burner out of the Control Box.
4. Clean by use of a stiff brush to remove any deposits.

19.3) REMOVING INJECTOR

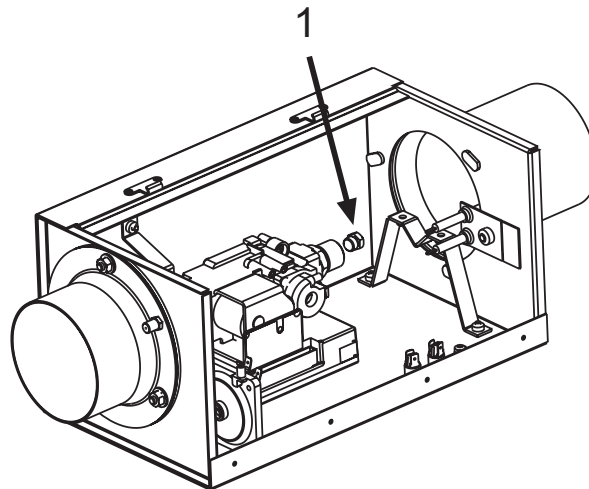

Fig. 42

1. Remove the Burner as described at above. Unscrew the Injector from the Injector Fitting, using a spanner, whilst retaining the Injector Fitting with a second spanner.
2. Inspect the Injector and clean as necessary with a soft bristle brush.

DO NOT DAMAGE THE INJECTOR ORIFICE BY USE OF SOLID OBJECTS.

19.4) REMOVING IGNITION CONTROL

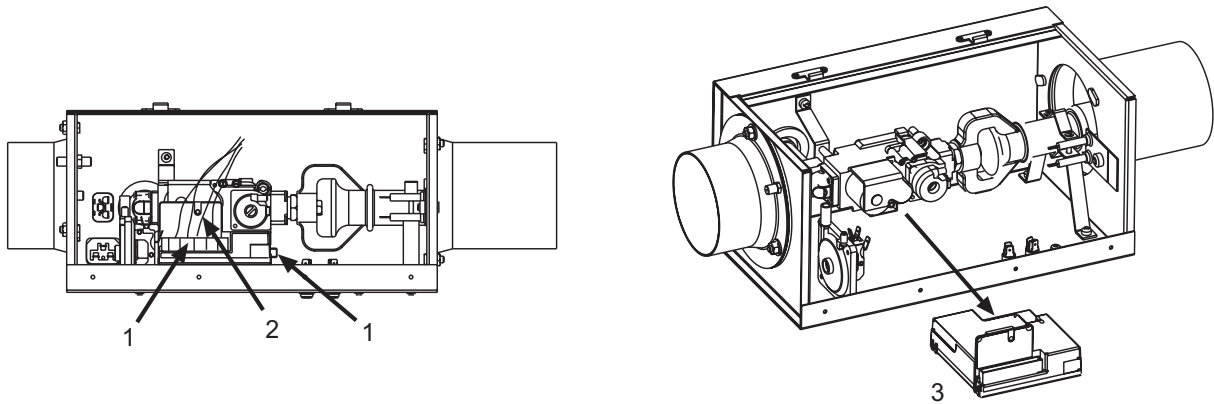

Fig. 43

1. Disconnect the 12 way Molex electrical connector and the grey HT ignition spark/flame sensor lead from the Ignition Control.
2. Unscrew the M3 screw securing the Ignition Control to the Control Valve.
3. Slide out the Ignition Control.

19.5) REMOVING AIR SWITCH

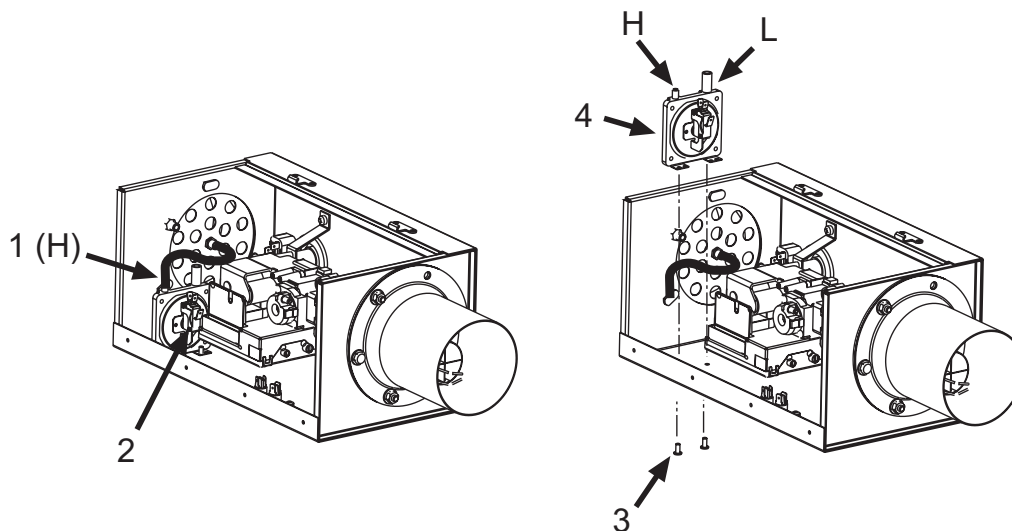

Fig. 44

1. After opening the control box door, remove the Air Tube Assembly from the Air Switch pressure connection marked 'H'.
2. Disconnect the three electrical leads from the Air Switch by gently pulling the connectors, using pliers.
3. Unscrew the two No. 8 x 12 self tapping screws securing the Air Proving Switch to the floor of the Control box and lift out with the electrical leads attached.
4. Remove the Air Switch, and remove the restrictor from the Air Switch connection marked 'L'.

When installing a replacement Air Switch, take care to connect the electrical leads in accordance with the wiring diagram shown in (Section 13 and replace the restrictor on the pressure connection marked "L". The appliance will not function unless this restrictor is in place

19.6) REMOVING GAS VALVE AND MANIFOLD ASSEMBLY

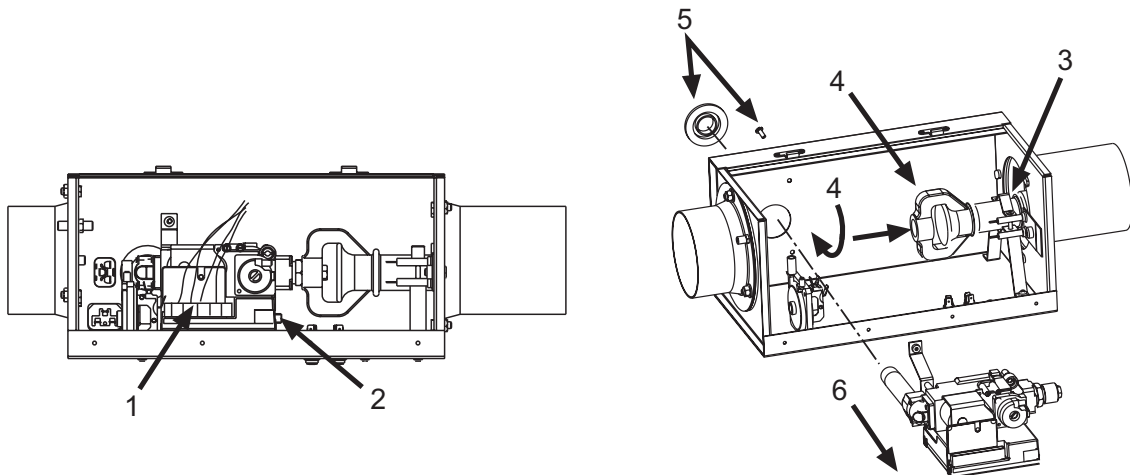

Fig. 45

1. After opening the control box door, disconnect the 12 way Molex electrical connector.
2. Disconnect the grey HT ignition spark/flame sensor lead from the ignition module.
3. Unscrew the two M4x25 setscrews from the burner bracket and remove the burner clamp.
4. Unscrew the burner and slide it away from the valve.
5. Unscrew the M4 screw securing the valve bracket to the control valve and remove the grommet.
6. Slide out the complete assembly of gas valve, ignition module and manifold.

After replacing the Control Valve, check the gas pressures in accordance with Section 0 of this manual.

IMPORTANT: TEST FOR GAS SOUNDNESS USING A SUITABLE LEAK DETECTION FLUID.

19.7) REMOVING NEON INDICATOR

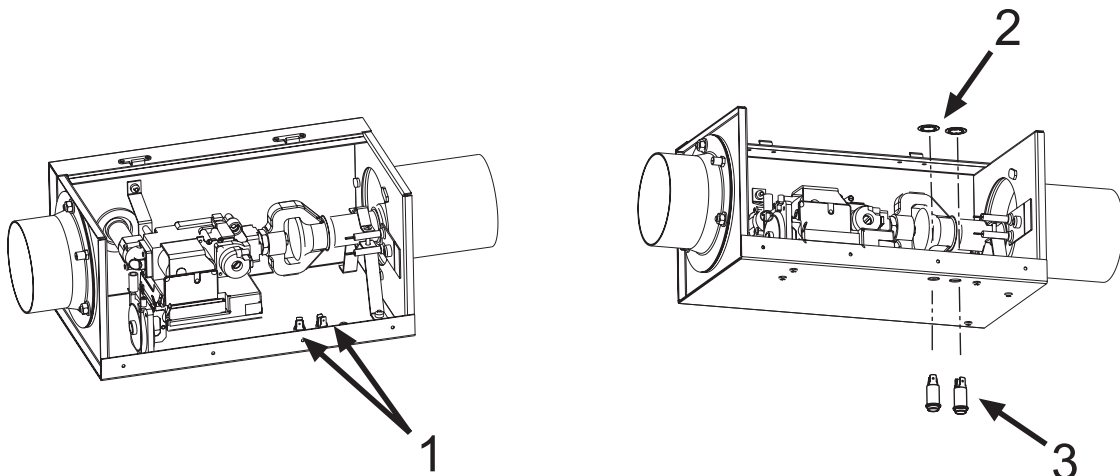

Fig. 46

1. Disconnect the electrical leads from the Neon Indicators by gently pulling the connectors, using pliers.
2. Remove the star washers.
3. Press the neon indicator out through the mounting hole in the floor of the control box.

When replacing a Neon Indicator, connect the electrical leads in accordance with the wiring diagram shown in (Section 13).

19.8) REMOVING AIR INLET PLATE

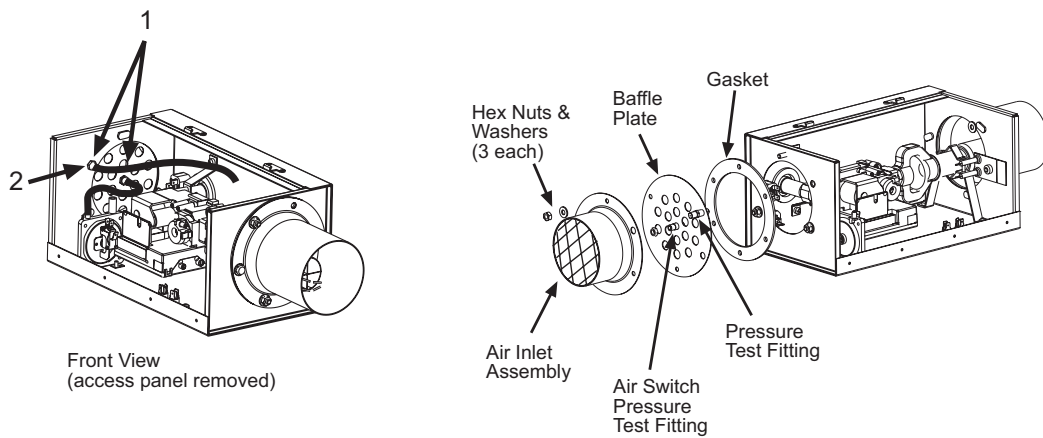

Fig. 47

1. After opening the control box door, disconnect tubing from both brass pressure test fittings.
2. Remove brass nut from pressure test fitting.
3. Disassemble components from the control box.

19.9) REMOVING THE FAN

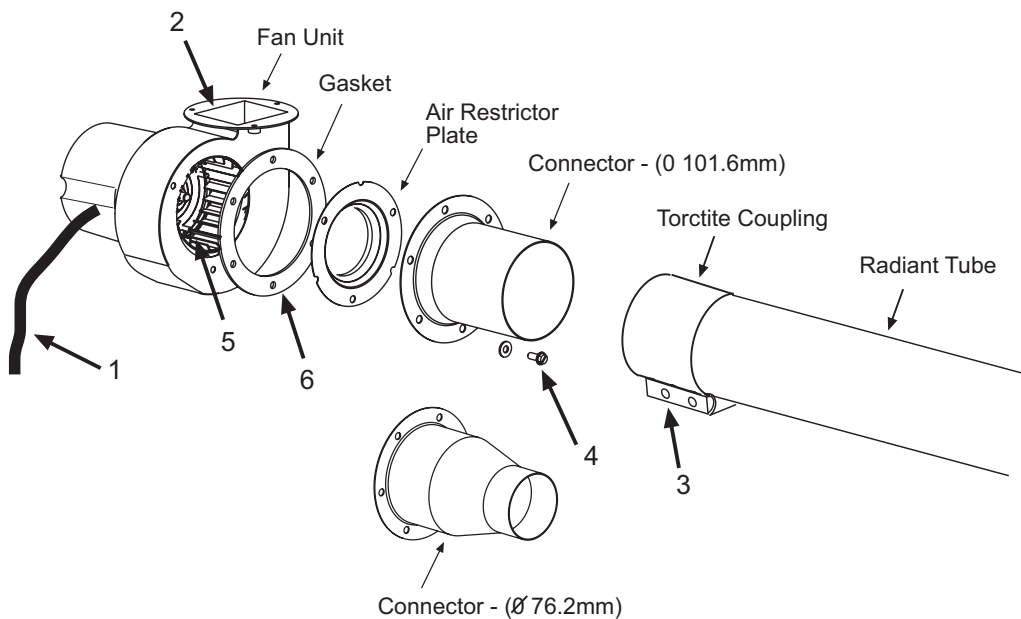

Fig. 48

1. Disconnect the electrical wires from the fan (see Section 13 for connection details).
2. If a flued installation, disconnect the flue from the Fan.
3. Loosen the nuts of the Torctite Coupling securing the Fan Connector to the Radiant Tube and draw the Fan Assembly off the Radiant Tube.
4. Unscrew the three M6 x 12 setscrews securing the Connector and Orifice Plate to the fan.
5. Inspect the main impeller and secondary cooling impeller and remove any dust by brushing with a soft brush. Check that the impeller rotates freely and that there is no excessive play in the bearings. The bearings are pre-lubricated and require no attention.
6. When re-assembling the Orifice Plate and Connector, a new Gasket must be fitted between the Fan housing and Orifice Plate (see Fig. 48).

20.0) CONVERSION INSTRUCTIONS

CONVERSION FROM CAT. 2H (Natural Gas) TO CAT. 3P (LPG)

- Remove the Injector from the Injector Fitting (see Section 0 and replace it with the alternative Injector supplied with conversion kit. Check that the size reference marked on the Injector agrees with that listed in the Specifications table (Section 5.0) for the appliance model in question.
- Remove the pressure governor cap from the integral pressure governor of the Control Valve and screw the adjuster clockwise to increase the gas pressure, check supply and manifold pressure in accordance with Section 11. Replace the pressure governor cap.
- Affix the gas adjustment label (3P G31 37mbar) supplied with conversion kit onto the Data Label, adjacent to the headings "Adjusted For" and "Setting Pressure", to cover the original gas adjustment label (2H, G20, 20mbar).
- Carry out checks in accordance with Section 11 of this manual to ensure correct supply pressure relative to the gas type being used (G31 – Propane).

CONVERSION FROM CAT. 3P (LPG) TO CAT. 2H (Natural Gas)

- Remove the Injector from the Injector Fitting (see Section 0 and replace it with the alternative Injector supplied with conversion kit. Check that the size reference marked on the Injector agrees with that listed in the Technical Data table (Section 5.0) for the appliance model in question.
- Remove the pressure governor cap from the integral pressure governor of the Control Valve and unscrew the adjuster counter clockwise to increase the gas pressure, check supply and manifold pressure in accordance with Section 0. Replace the pressure governor cap.
- Affix the gas adjustment label (2H, G20, 20mbar) supplied with conversion kit onto the Data Label adjacent to the headings, "Adjusted For" and "Setting Pressure" to cover the original gas adjustment label (3P, G31, 37mbar).
- Carry out checks in accordance with Section 0 of this manual to ensure correct supply pressure and setting pressure, relative to the gas type being used (G20 - Natural Gas).

21.0) INSTALLATION DATA

Date of Installation: _____ # of Heaters in System: _____

Serial No. _____

Model: _____

N = Natural Gas
L = Propane Gas

22.0) REPLACEMENT PARTS GUIDE

The following is a list of replacement parts which may be required during the life of the appliance.

CONTROL COMPONENTS			
Item No.	Part No.	Description	Qty.
1	02330010	Vinyl Cap	1
2	02331010	Plug, Liquid Tight Hole	1
3	4262151	Inlet – Male Pin #PX0575	1
3a	4262153	Outlet – Female #PX0695	1
4	30700040	Grommet, Pipe Sealing	1
5			
6	42602870	Housing (welded)	1
7	4250694	Access Panel (with hinge)	1
8	44202000	Turnbuckle Holder Bracket	1
8a	30545040	Turnbuckle (Not shown)	1
9	03988070	Tubing, Silicone – 178mm Lg. (Not shown)	2
10	2113	Pressure Test Point	1
11	4260363	Test Nipple	1
12	4262322	Brass Locknut	2
13	4250600	Burner Fabrication	1
13a	42700000	Burner (25kw controls only)	
14	4250625	Air Switch Assembly	1
15	4250696	Gas Valve Assembly (complete)	1
15a	4262586	Gas Valve #VK4105C	1
15b	4262552	Flange, 1/2 BSPT - Straight	1
15c	4260502	Pipe Nipple, 1/2 BSPT x 110mm	1
15d	4260382	Valve Bracket	1
15e	4262551	Flange, 1/2 BSPT - Elbow	1
16	42506950	Wiring Harness – less HI Tension Cable (Not shown)	1
17	42510929	Hi Tension Cable – 178mm Lg. (Not shown)	1
18	4260132	Gasket	2
19	4260364	Injector Fitting – 1/2 BSPT x 7/8 UNF	1
19a	42701000	Injector Fitting – 1/2 NPT x 5/8 UNF (25kw controls only)	1
19b	03540090	Coupling – 1/2 NPT (25kw controls only)	1
19c	03333040	Pipe Nipple, 1/2 NPT x 38mm (25kw control only)	1
20	4260367	Burner Clamp	1
21	4260370	Connector – 76.2mm (shown)	1
21a	4260371	Connector – 101.6mm	1
22	4260380	Burner Bracket	1
23	4260541	Electrode	1
24	4262197	Ignition Control	1
25	4262280	Neon Light - Red (round)	1
26	4262281	Neon Light - Amber (round)	1
27	xxxxxxx	Gas Injector (State Model & Gas Type for Size)	1
28	4260360x	Baffle Plate (State Model & Gas Type for Size)	1
29	4260362	Air Inlet Fabrication	1

LABELS/MANUAL			
Item No.	Part No.	Description	Qty.
30	4262036	Label Neon	1
31	4262035	Label, Fan/Power Supply	1
32	4260420	Label, Warning - GB/IE	1
33	43344120GB	Label, Clearances to Combustibles	1
34	42848130GB	Label, Nameplate	1
35	4260440	Label, Operating Instructions - GB	1
36	4262000	Label, Space-Ray Logo	1
37	44201090	Installation/Operation Manual	1

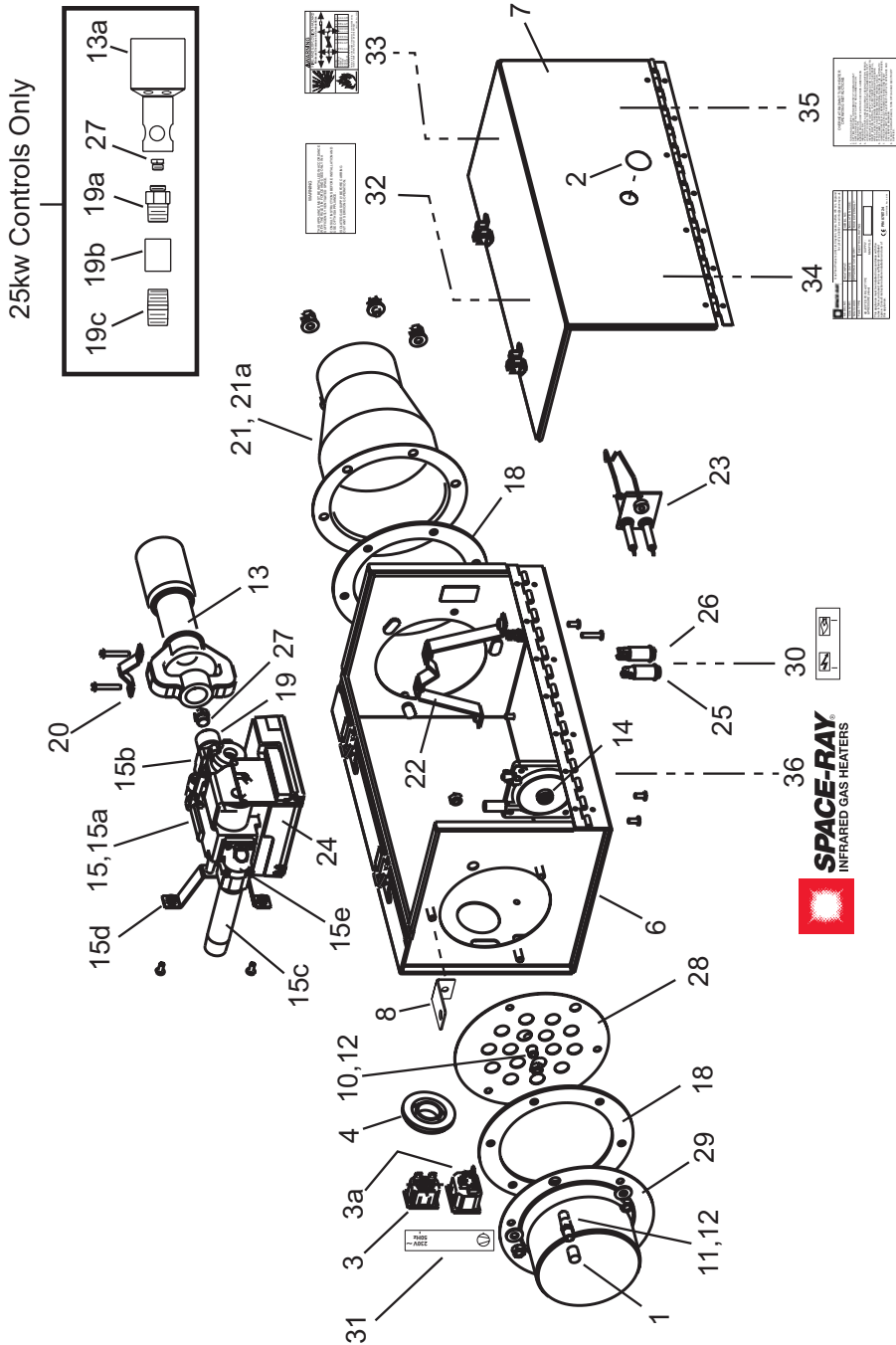

Fan Assembly			
Item No.	Part No.	Description	Qty.
1	4262256	Fan Unit – Airflow #45BTFR	1
2	4260132	Gasket	1
3	4260361x	Orifice Plate (State Model & Gas Type for Size)	1
4	4260370	Connector – (for 76.2mm dia. tube)	1
5	4260371	Connector – (for 101.6mm dia. tube)	1
6	44200010	Flue Screen Outlet Plate - 103 x 113mm (accessory)	1
7	4267261	M6 x 16mm Hex Head Setscrews	6
7a	4267266	M6 Spring Lockwashers	6

